

500 GR

- (1) ★ 56156990V
- 31121007
- 31421083

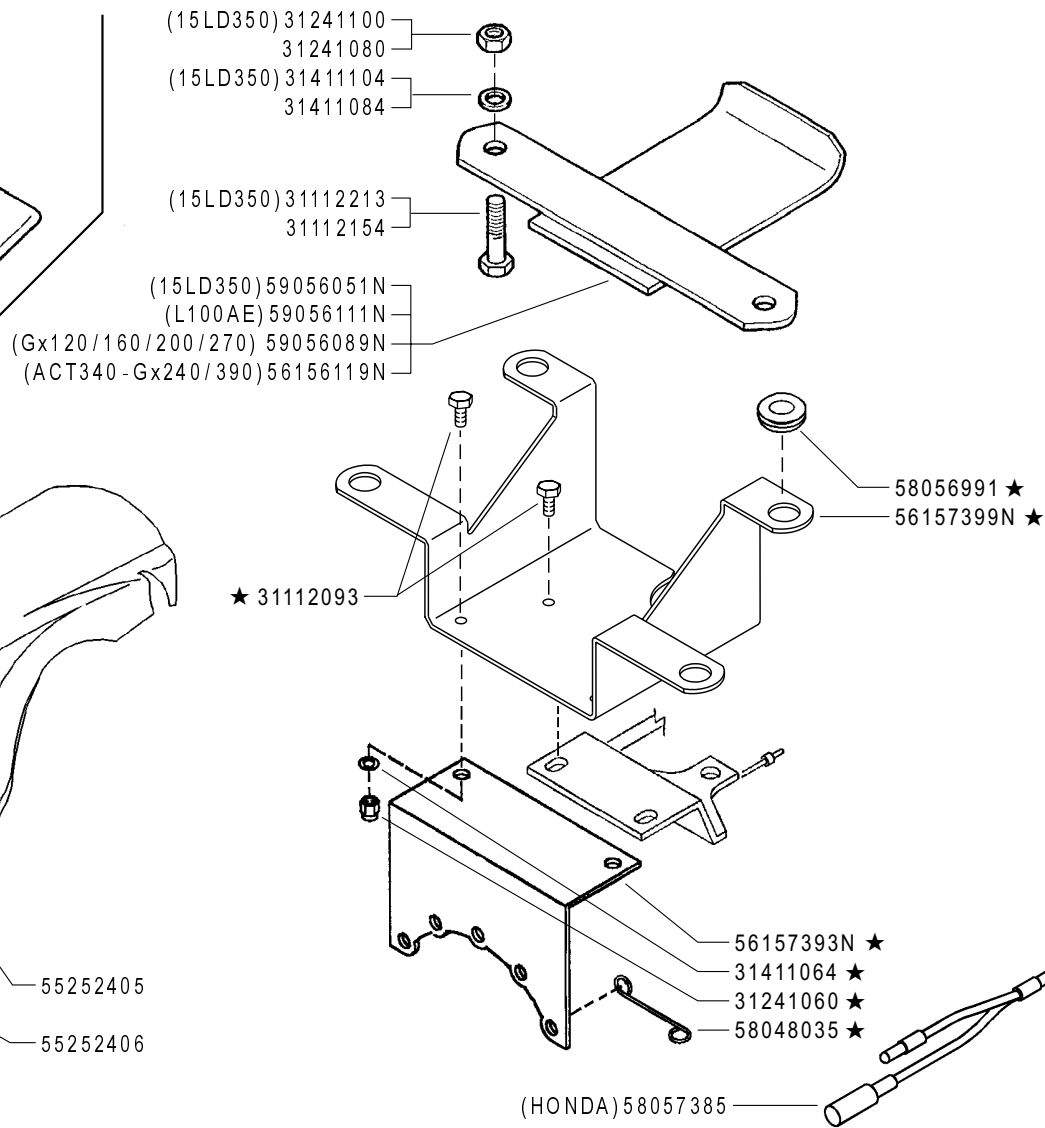
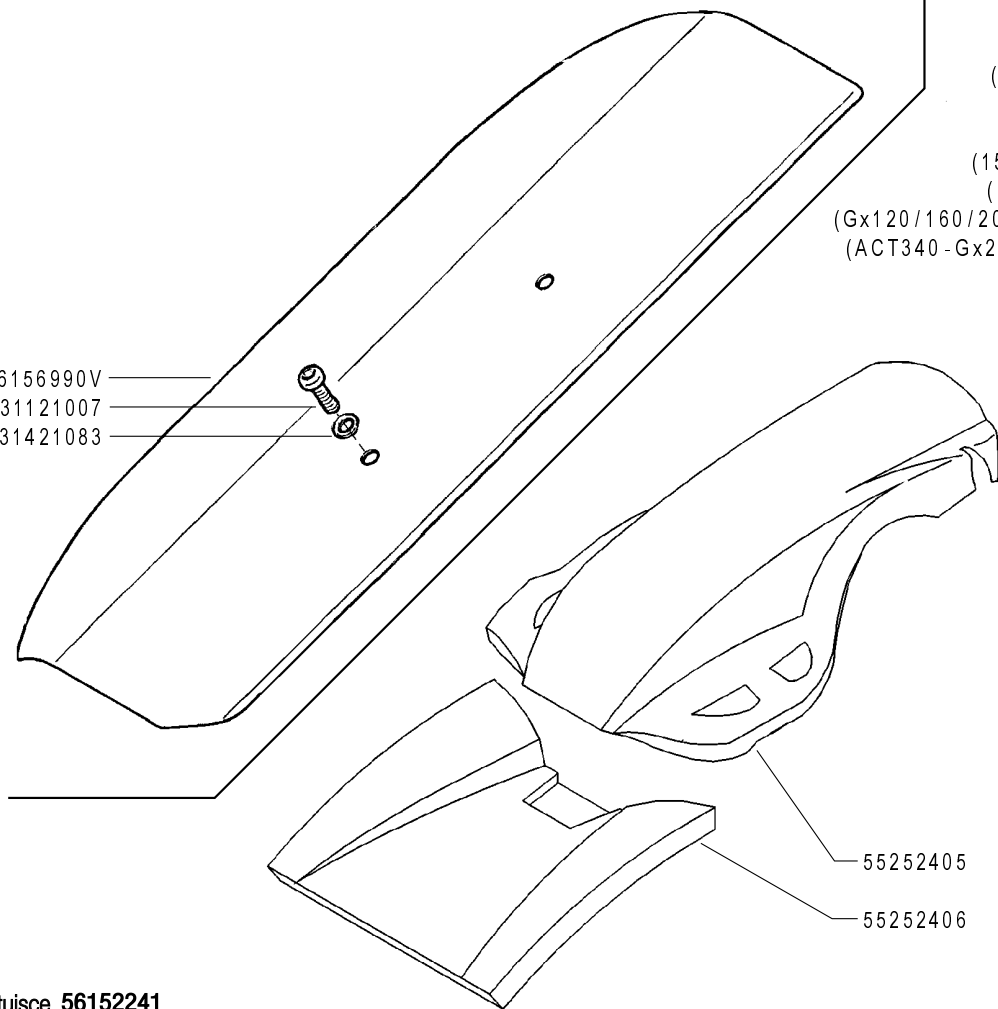

(1) sostituisce 56152241

FERRARI

500 serie **GRIFON**

RIPARI MOTORE

(500GR - 515GR - 515L GR - 515S GR - 515SL GR ★)

ENGINE GUARDS
PROTECCIONES MOTOR

PROTECTIONS MOTEUR
MOTOR SCHUTZ

DALLA MACCHINA
DE LA MAQUINA
DE LA MACHINE
FROM THE MACHINE
AB DER MASCHINE

★N.

AGGIORNAMENTO
REVISION
MISE A JOUR
APLAZAMIENTO
ANPASSUNG

C01

Rev.
2

02/2009

ZENNE

Pos.	Code	Q.ty	Description	Notes
0	0	1		
31112093	31112093	1	SCREW TE M6X20 UNI 5739 8G	
31112154	31112154	1	SCREW TE M8X40 UNI 5739 8G	
31112213	31112213	1	SCREW TE M10X40 UNI 5739	
31121007	31121007	1	SCREW BCEI M8X20 ISO7380	
31241060	31241060	1	SELFLOCK NUT M6	
31241080	31241080	1	SELFLOCK NUT M8	
31241100	31241100	1	SELFLOCK NUT M10 6S	
31411064	31411064	1	WASHER 6,4x12,5	
31411084	31411084	1	WASHER 8,4x17	
31411104	31411104	1	WASHER 10,5x18	
31421083	31421083	1	WASHER	
55252405	55252405	1	GUARD	
55252406	55252406	1	GUARD	
58048035	58048035	1	HOLDER	
58056991	58056991	1	CABLE GLAND	
58057385	58057385	1	LINE	
59056111	59056111	1	SHIELD	
56156119	56156119N	1	SHIELD	
56156990	56156990V	1	BODYWORK	
56157393	56157393N	1	HOLDER	
56157399	56157399N	1	HOLDER	
59056051	59056051N	1	SHIELD	
59056089	59056089N	1	SHIELD	

500 GR

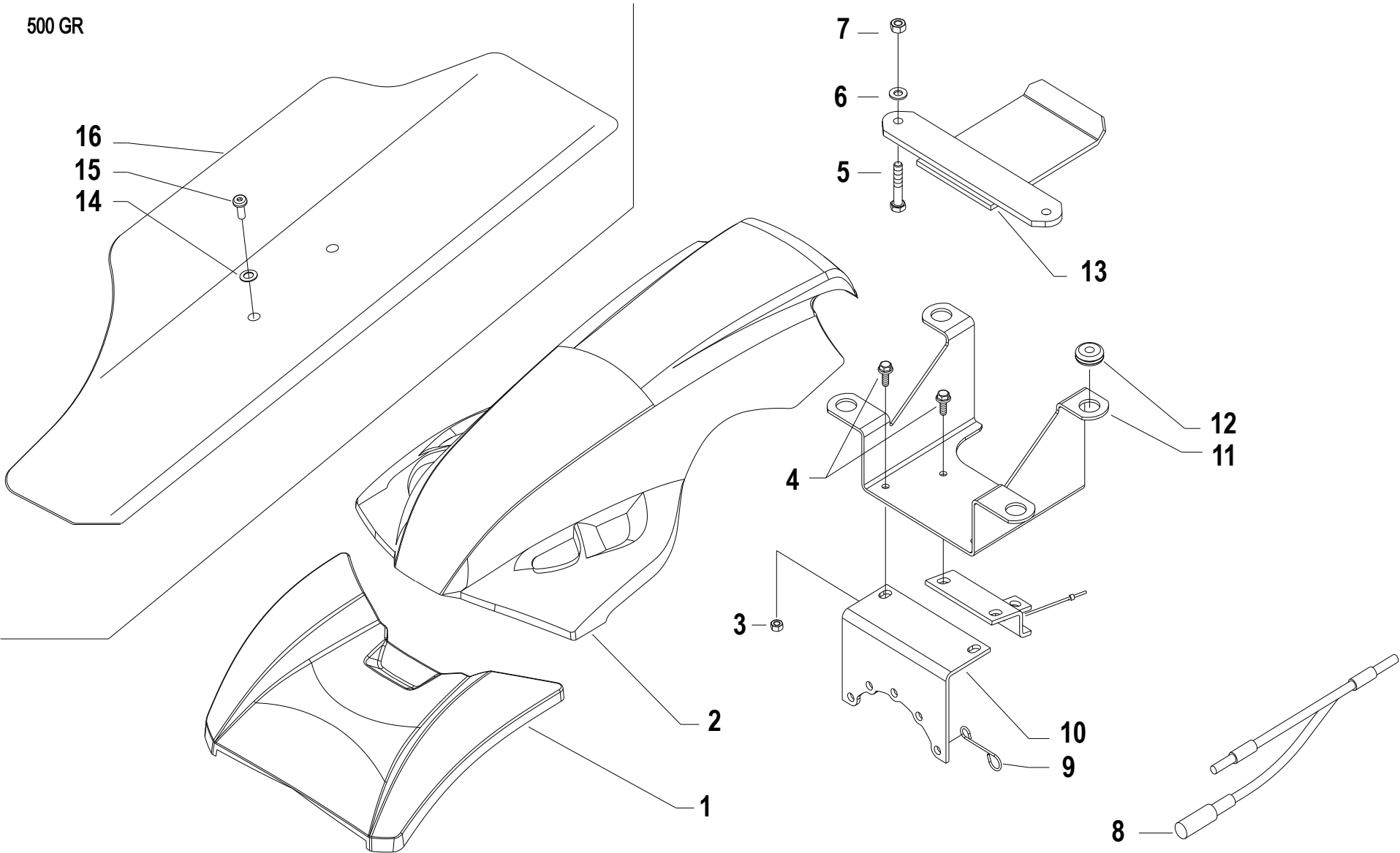

Pos.	Code	Q.ty	Description	Notes
1	55252406	1	GUARD	
2	55252405	1	GUARD	
3	31241065	1	SELFLOCK NUT M6	
4	31112085	1	SCREW TE M6X16 DIN 6921 8G	
5	31112154	1	SCREW TE M8X40 UNI 5739 8G	
5	31112213	1	SCREW TE M10X40 UNI 5739	For the engine 15LD350
6	31411084	1	WASHER 8,4x17	
6	31411104	1	WASHER 10,5x18	For the engine 15LD350
7	31241080	1	SELFLOCK NUT M8	
7	31241100	1	SELFLOCK NUT M10 6S	For the engine 15LD350
8	58057385	1	LINE	
9	58048035	1	HOLDER	
10	56157393N	1	HOLDER	
11	56157399N	1	HOLDER	
12	58056991	1	CABLE GLAND	
13	56156119N	1	SHIELD	For motors ACT340 / GX240 / GX270 / GX390
13	59056051	1	SHIELD	For the engine 15LD350
13	59056089N	1	SHIELD	For motors GX120 / GX160 / GX200 / EX21
13	59056111N	1	SHIELD	For the engine L100AE
14	31421083	1	WASHER	
15	31121007	1	SCREW BCEI M8X20 ISO7380	
16	56156990V	1	BODYWORK	

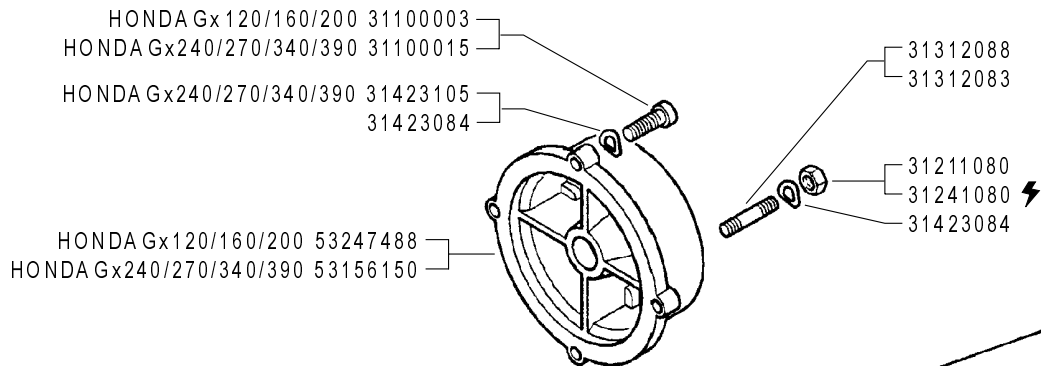

MOTORE ENGINE MOTEUR MOTOR MOTOR	FRIZIONE CLUTCH A EMBRAYAGE EMBRAGUE KUPPLUNG
Acme A220	59247884
Acme ACT 280 - A349 - A360	59247884
Acme ACT 340	59247971
Honda Gx390 - Gx340 D=25,4	59256280
Honda Gx240/270 D=25,4	59256279
Honda Gx120/160/200 D=19	59256275
Lombardini 15LD315/350	59247884
Lombardini 15LD500	59247924
Lombardini LGA 340 ★	59247971
Yanmar L100AE	59247971
Yanmar L70AE	59247884

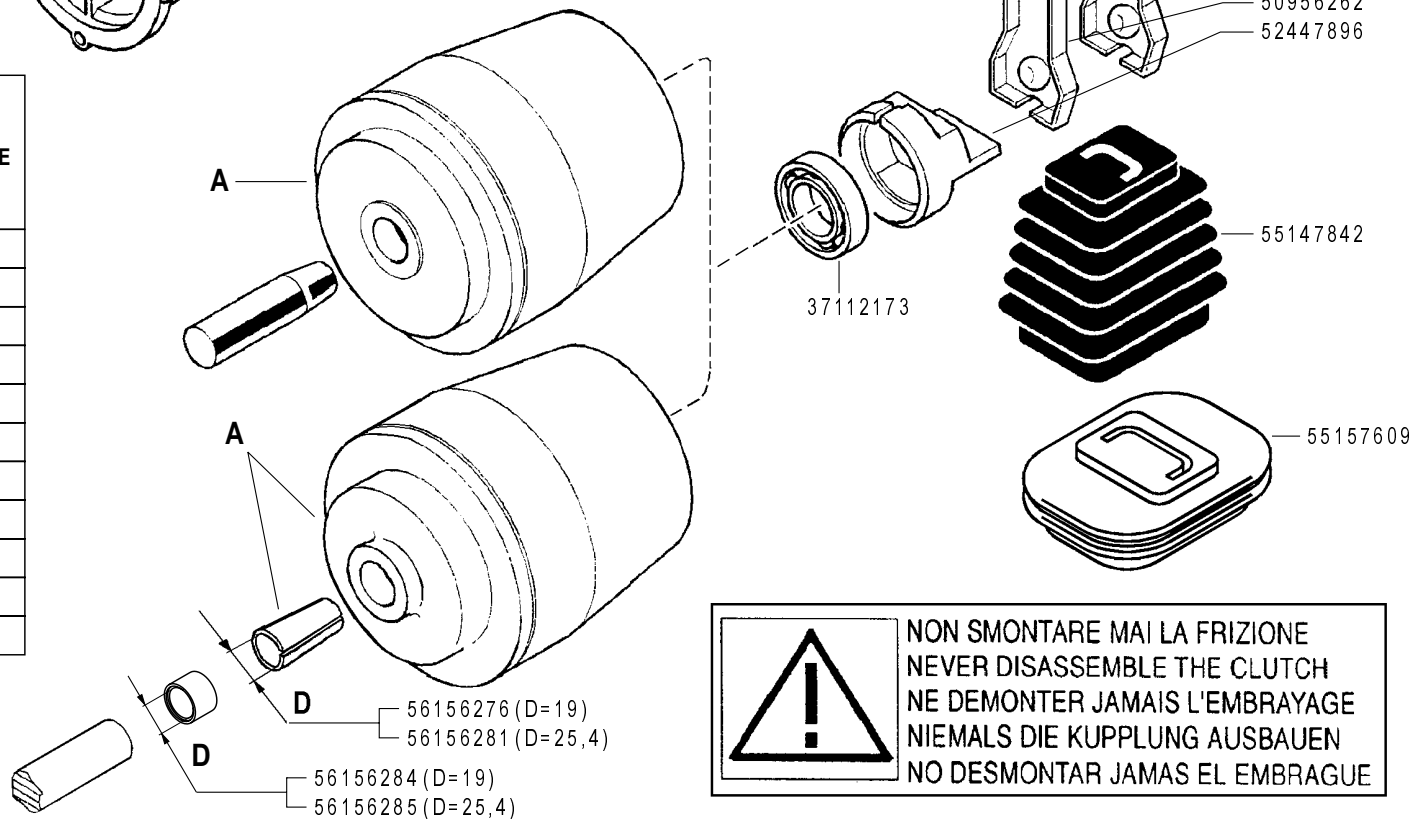

! NON SMONTARE MAI LA FRIZIONE
NEVER DISASSEMBLE THE CLUTCH
NE DEMONTER JAMAIS L'EMBRAYAGE
NIEMALS DIE KUPPLUNG AUSBAUEN
NO DESMONTAR JAMAS EL EMBRAGUE

FERRARI

500 serie GRIFON

FRIZIONE A CONO AUTOVENTILANTE

CLUTCH
EMBRAGUE

EMBRAYAGE
KUPPLUNG

DALLA MACCHINA
DE LA MAQUINA
DE LA MACHINE
FROM THE MACHINE
AB DER MASCHINE

AGGIORNAMENTO

REVISION

MISE A JOUR

APLAZAMIENTO

ANPASSUNG

D01

Rev.
3

01/2009

★ N.

ZENNE

Pos.	Code	Q.ty	Description	Notes
31100003	31100003	1	SCREW TE 5/16X7/8	
31100015	31100015	1	SCREW TE 3/8X1	
31211080	31211080	1	NUT M8	
31241080	31241080	1	SELFLOCK NUT M8	
31312083	31312083	1	STUD BOLT M8X46X16X16	
31312088	31312088	1	STUD BOLT M8X40X14X14	
31423084	31423084	1	SPRING WASHER 8,4	
31423105	31423105	1	SPRING WASHER 10,5	
37112173	37112173	1	BEARING	
50956262	50956262	1	CLUTCH LEVER	
52447896	52447896	1	PRESSURE PLATE	
53156150	53156150	1	ENGINE FLANGE	
53247488	53247488	1	ENGINE FLANGE	
55147842	55147842	1	BELLOWS	
55157609	55157609	1	BELLOWS	
56147845	56147845	1	CLUTCH LEVER	
56156276	56156276	1	SLEEVE	
56156281	56156281	1	CENTRING BUSH	
56156284	56156284	1	SPACER	
56156285	56156285	1	SPACER	
59247884	59247884	1	CLUTCH ASSY	
59247924	59247924	1	CLUTCH	
59247971	59247971	1	CLUTCH	
59256275	59256275	1	CLUTCH ASSY	
59256279	59256279	1	CLUTCH ASSY	
59256280	59256280	1	CLUTCH ASSY	

SERIAL

CLUTCH

CODE REV

D01_3_59819

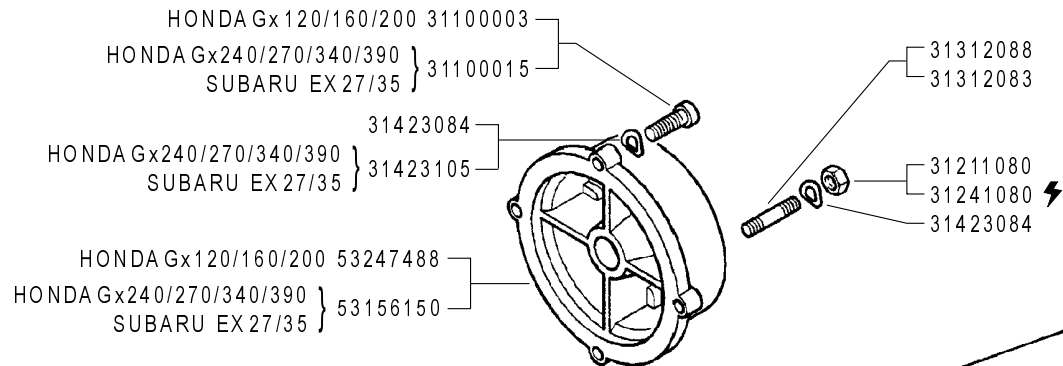

MOTORE ENGINE MOTEUR MOTOR MOTOR	FRIZIONE CLUTCH A EMBRAYAGE EMBRAGUE KUPPLUNG
Acme A220	59247884
Acme ACT 280 - A349 - A360	59247884
Acme ACT 340	59247971
Honda Gx390 - Gx340 D=25,4	59256280
Honda Gx240/270 D=25,4	59256279
Honda Gx120/160/200 D=19	59256275
Lombardini 15LD315/350	59247884
Lombardini 15LD500	59247924
Lombardini LGA 340	59247971
Subaru EX 27 ★	59256279
Subaru EX 35 ★	59256280
Yanmar L100AE	59247971
Yanmar L70AE	59247884

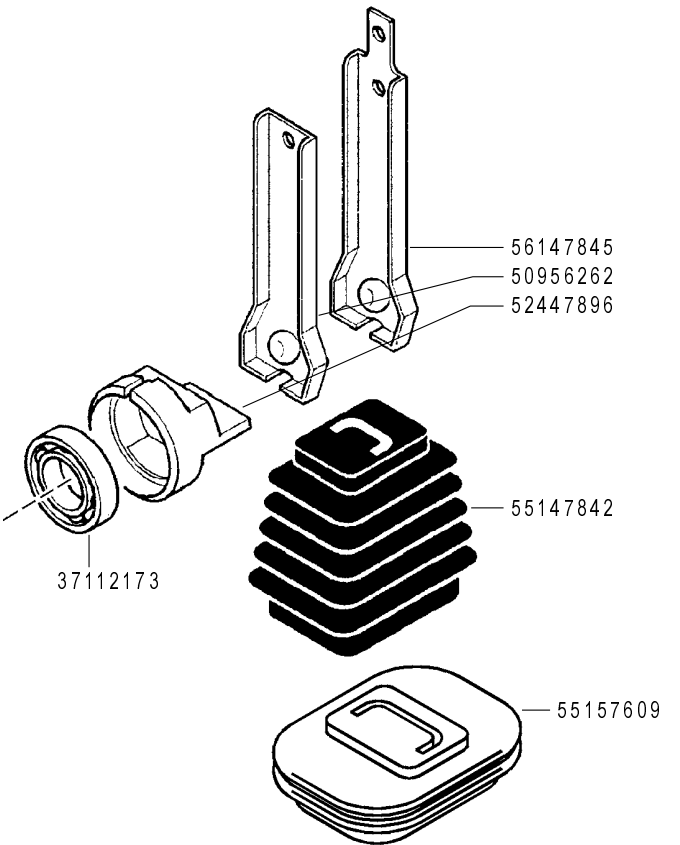
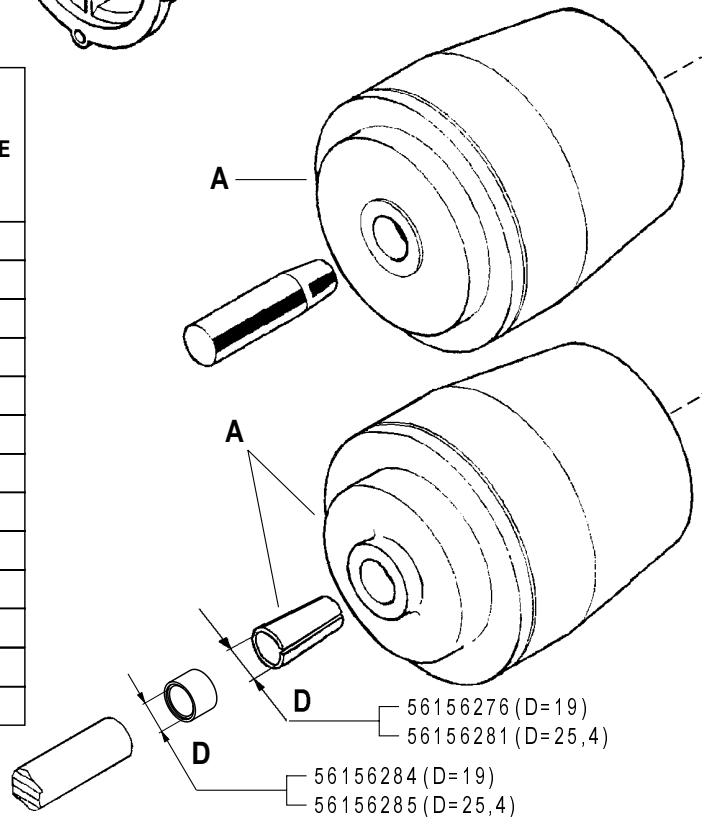

 **NON SMONTARE MAI LA FRIZIONE
NEVER DISASSEMBLE THE CLUTCH
NE DEMONTER JAMAIS L'EMBRAYAGE
NIEMALS DIE KUPPLUNG AUSBAUEN
NO DESMONTAR JAMAS EL EMBRAGUE**

FERRARI

500 serie **GRIFON**

FRIZIONE A CONO AUTOVENTILANTE

CLUTCH
EMBRAGUE

EMBRAYAGE
KUPPLUNG

DALLA MACCHINA
DE LA MAQUINA
FROM THE MACHINE
AB DER MASCHINE

AGGIORNAMENTO

REVISION

MISE A JOUR

APLAZAMIENTO

ANPASSUNG

D01

Rev. **4**

03/2010

★ N.

ZENNE

Pos.	Code	Q.ty	Description	Notes
31100003	31100003	1	SCREW TE 5/16X7/8	
31100015	31100015	1	SCREW TE 3/8X1	
31211080	31211080	1	NUT M8	
31241080	31241080	1	SELFLOCK NUT M8	
31312083	31312083	1	STUD BOLT M8X46X16X16	
31312088	31312088	1	STUD BOLT M8X40X14X14	
31423084	31423084	1	SPRING WASHER 8,4	
31423105	31423105	1	SPRING WASHER 10,5	
37112173	37112173	1	BEARING	
50956262	50956262	1	CLUTCH LEVER	
52447896	52447896	1	PRESSURE PLATE	
53156150	53156150	1	ENGINE FLANGE	
53247488	53247488	1	ENGINE FLANGE	
55147842	55147842	1	BELLOWS	
55157609	55157609	1	BELLOWS	
56147845	56147845	1	CLUTCH LEVER	
56156276	56156276	1	SLEEVE	
56156281	56156281	1	CENTRING BUSH	
56156284	56156284	1	SPACER	
56156285	56156285	1	SPACER	
59247884	59247884	1	CLUTCH ASSY	
59247924	59247924	1	CLUTCH	
59247971	59247971	1	CLUTCH	
59256275	59256275	1	CLUTCH ASSY	
59256279	59256279	1	CLUTCH ASSY	
59256280	59256280	1	CLUTCH ASSY	

SERIAL

CLUTCH

CODE REV

D01_4_72864

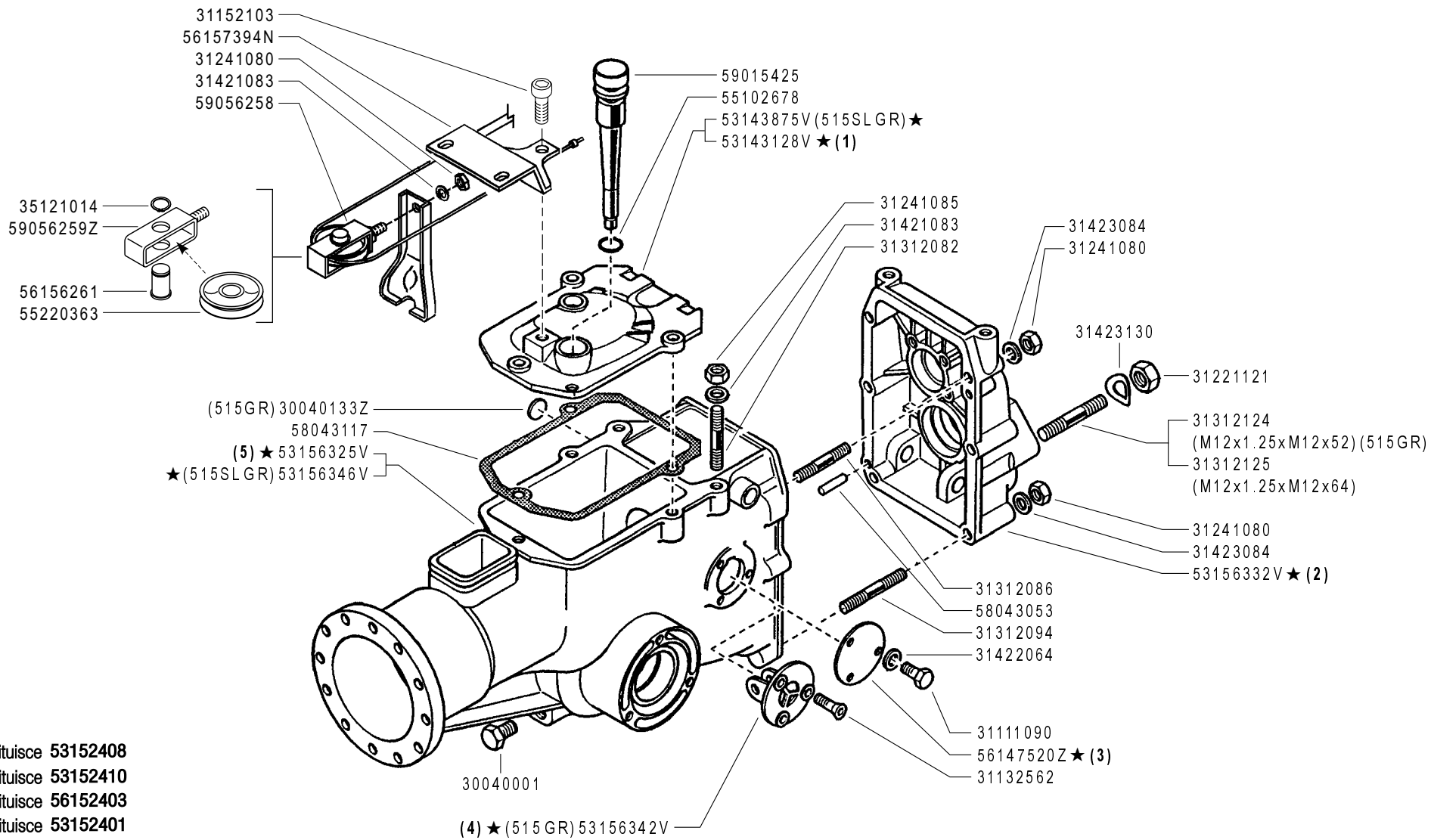

- (5) sostituisce 53152408
- (4) sostituisce 53152410
- (3) sostituisce 56152403
- (2) sostituisce 53152401
- (1) sostituisce 53152409

FERRARI

500 serie GRIFON

**SCATOLA CAMBIO
(515GR - 515L GR - 515S GR - 515SL GR ★)**

GEARBOX
CAJA DE CAMBIO

BOITE DE VITESSES
WECHSELGETRIEBE

DALLA MACCHINA
DE LA MAQUINA
DE LA MACHINE
FROM THE MACHINE
AB DER MASCHINE

★N.

AGGIORNAMENTO
REVISION
MISE A JOUR
APLAZAMIENTO
ANPASSUNG

E01

Rev.
2

02/2009

ZENNE

Pos.	Code	Q.ty	Description	Notes
30040001	30040001	1	PLUG	
31111090	31111090	1	SCREW TE M5X10 UNI 5739 8G	
31132562	31132562	1	SCREW TSVEI M6X16 UNI 5933	
31152103	31152103	1	SCREW TCEI M10X25 UNI 5931	
31221121	31221121	1	NUT M12X1,25	
31241080	31241080	1	SELFLOCK NUT M8	
31241085	31241085	1	SELFLOCK NUT M8 6S	
31312082	31312082	1	STUD BOLT M8X38X14X20	
31312086	31312086	1	STUD BOLT M8X56X20X14	
31312094	31312094	1	STUD BOLT M8X68X14X36	
31312124	31312124	1	STUD BOLT	
31312125	31312125	1	STUD BOLT	
31421083	31421083	1	WASHER	
31422064	31422064	1	SPRING WASHER 6,4	
31423084	31423084	1	SPRING WASHER 8,4	
31423130	31423130	1	SPRING WASHER 13	
35121014	35121014	1	SEEGER RING E 14 DIN 471	
55102678	55102678	1	RUBBER RING	
55220363	55220363	1	PULLEY	
56156261	56156261	1	PIN	
58043053	58043053	1	CYLINDRICAL PLUG	
58043117	58043117	1	COVER GASKET	
59015425	59015425	1	PLUG	
59056258	59056258	1	CLUTCH FORK	
30040133	30040133Z	1	PLUG 22 DIN 470	
53143128	53143128V	1	COVER	
53143875	53143875V	1	GEARBOX HOUSING COVER	
53156325	53156325V	1	BODY	
53156332	53156332B	1	REAR COVER	
53156342	53156342V	1	GEAR SUPPORT	
53156346	53156346V	1	BODY	
56147520	56147520Z	1	COVER	
56157394	56157394N	1	STOP	
59056259	59056259Z	1	CLUTCH FORK	

SERIAL

GEARBOX

CODE REV

E01_2_67697

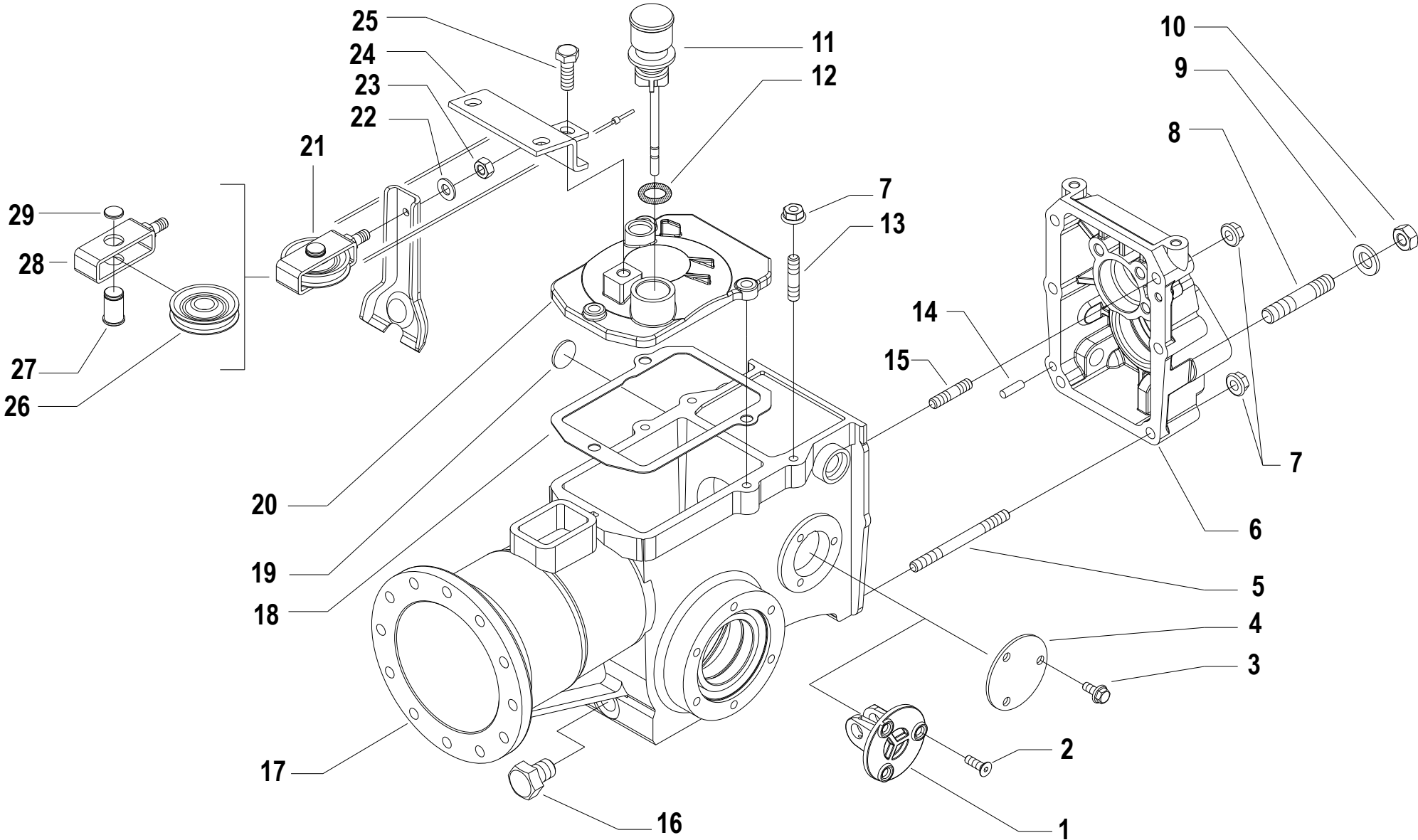

Pos.	Code	Q.ty	Description	Notes
1	53156342V	1	GEAR SUPPORT	
2	31132562	1	SCREW TSVEI M6X16 UNI 5933	
3	31112083	1	SCREW M6X12	
4	56147520Z	1	COVER	
5	31312094	1	STUD BOLT M8X68X14X36	
6	53156332V	1	REAR COVER	
7	31241084	1	SELFLOCK NUT M8 6S	
8	31312124	1	STUD BOLT	For the model 515G
8	31312125	1	STUD BOLT	
9	31421130	1	WASHER	
10	31221121	1	NUT M12X1,25	
11	59015425	1	PLUG	
12	55102678	1	RUBBER RING	
13	31312082	1	STUD BOLT M8X38X14X20	
14	58043053	1	CYLINDRICAL PLUG	
15	31312086	1	STUD BOLT M8X56X20X14	
16	30040001	1	PLUG	
17	53156325V	1	BODY	
17	53156346V	1	BODY	For the model 515SLGR
18	58043117	1	COVER GASKET	
19	30040133Z	1	PLUG 22 DIN 470	For the model 515GR
20	53143128V	1	COVER	
20	53143875V	1	GEARBOX HOUSING COVER	
21	59056258	1	CLUTCH FORK	
22	31421083	1	WASHER	
23	31241080	1	SELFLOCK NUT M8	
24	56157394N	1	STOP	
25	31152103	1	SCREW TCEI M10X25 UNI 5931	
26	55220363	1	PULLEY	
27	56156261	1	PIN	
28	59056259Z	1	CLUTCH FORK	
29	35121014	1	SEEGER RING E 14 DIN 471	

SERIAL

GEARBOX

CODE REV

E.01.02.A0011_03

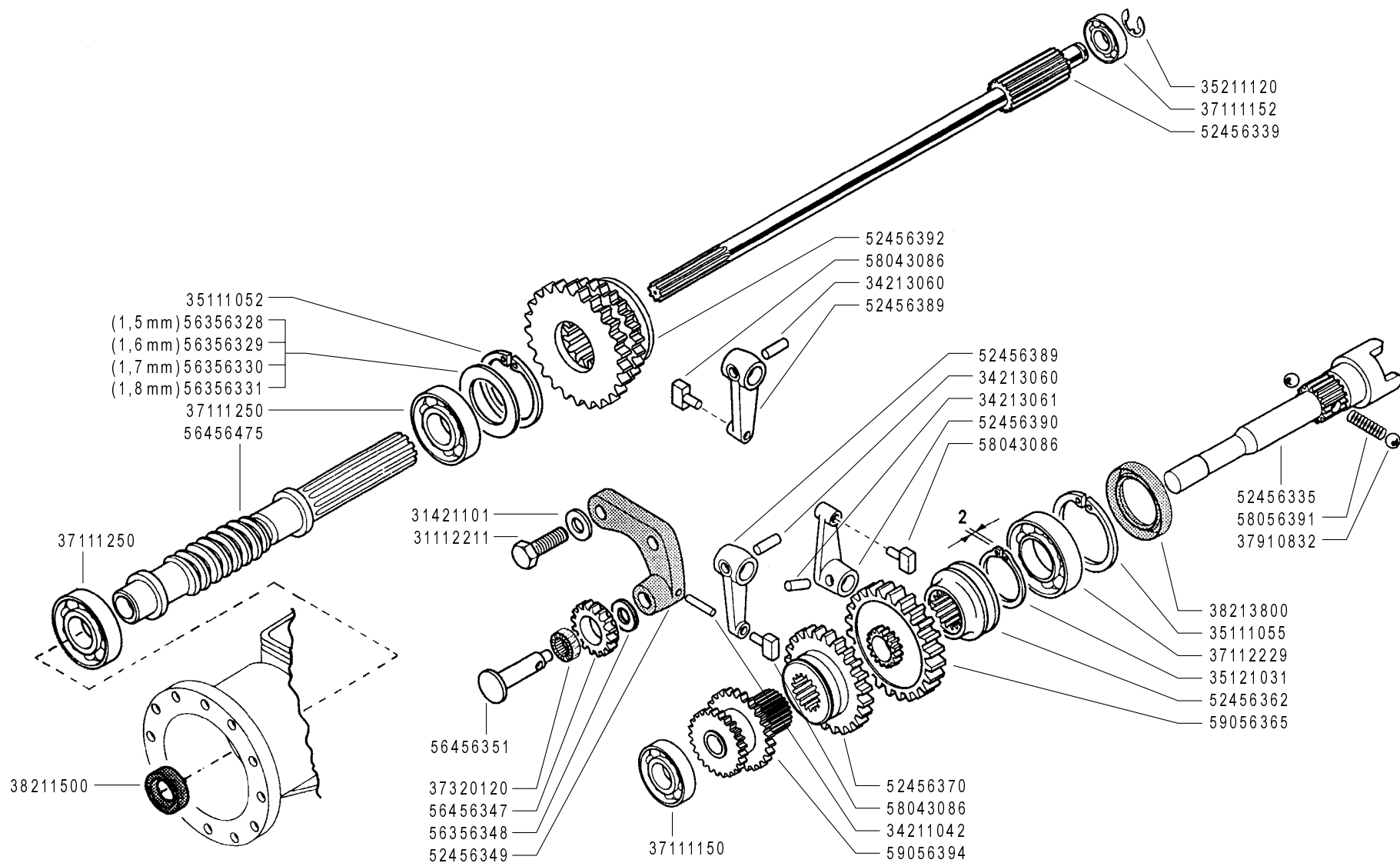

FERRARI

500 serie **GRIFON**

**INGRANAGGI CAMBIO
(515L GR - 515S GR - 515SL GR ★)**

GEARS
ENGRANAJES

ENGRANAGES
ZÄHNRÄDER

DALLA MACCHINA
DE LA MAQUINA
DE LA MACHINE
FROM THE MACHINE
AB DER MASCHINE

AGGIORNAMENTO

REVISION

MISE A JOUR

APLAZAMIENTO

ANPASSUNG

★N.

F02

02/2009

Rev.
2

ZENNE

Pos.	Code	Q.ty	Description	Notes
31112211	31112211	1	SCREW TE M10X30 UNI 5739	
31421101	31421101	1	WASHER	
34211042	34211042	1	ROLL PIN	
34213060	34213060	1	ROLL PIN	
34213061	34213061	1	ROLL PIN	
35111052	35111052	1	SEEGER RING I 52 DIN 472	
35111055	35111055	1	SEEGER RING I 55 DIN 472	
35121031	35121031	1	SEEGER RING E 30 UNI 7436	
35211120	35211120	1	SEEGER RING E 12 UNI 7434	
37111150	37111150	1	BEARING	
37111152	37111152	1	BEARING	
37111250	37111250	1	BEARING	
37112229	37112229	1	BEARING	
37320120	37320120	1	ROLLER CAGE 12X15/10	
37910832	37910832	1	BALL 1/4	
38211500	38211500	1	OIL SEAL 15X28X7	
38213800	38213800	1	OIL SEAL 38X55X7	
52456335	52456335	1	PTO SHAFT	
52456339	52456339	1	SHAFT	
52456349	52456349	1	GEAR SUPPORT	
52456362	52456362	1	COUPLING	
52456370	52456370	1	SLIDER	
52456389	52456389	1	LEVER	
52456390	52456390	1	LEVER	
52456392	52456392	1	SLIDER	
56356328	56356328	1	ADJUSTING RING SP=1,5	
56356329	56356329	1	ADJUSTING RING SP=1,6	
56356330	56356330	1	ADJUSTING RING SP=1,7	
56356331	56356331	1	ADJUSTING RING SP=1,8	
56356348	56356348	1	ADJUSTING RING	
56456347	56456347	1	GEAR	
56456351	56456351	1	GEAR PIN	
56456475	56456475	1	SCREW	
58043086	58043086	1	SHOE	

SERIAL

GEARS

CODE REV

F02_2_67738

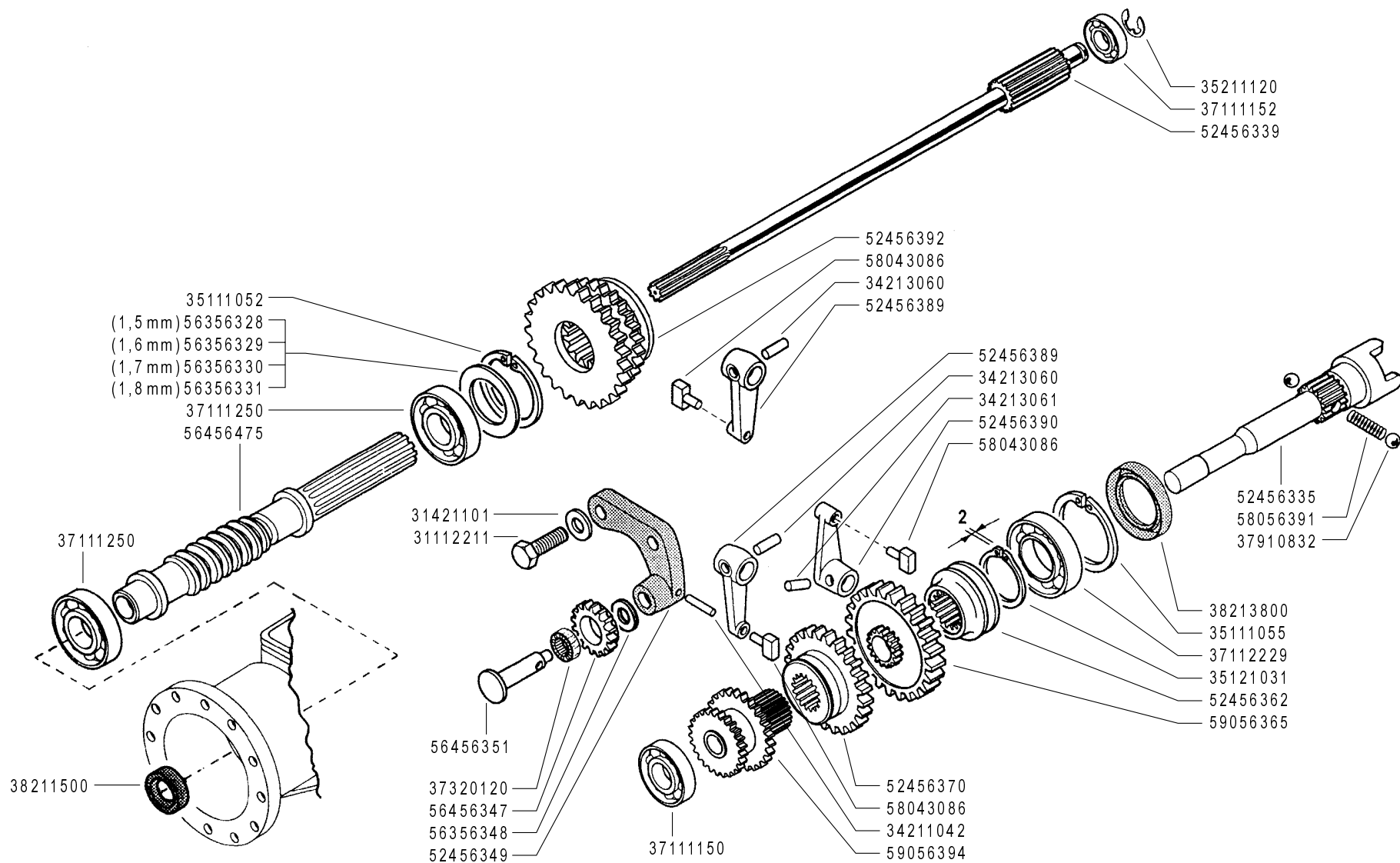

FERRARI

500 serie **GRIFON**

**INGRANAGGI CAMBIO
(515L GR - 515S GR - 515SL GR ★)**

GEARS
ENGRANAJES

ENGRANAGES
ZÄHNRÄDER

DALLA MACCHINA
DE LA MAQUINA
DE LA MACHINE
FROM THE MACHINE
AB DER MASCHINE

AGGIORNAMENTO

REVISION

MISE A JOUR

APLAZAMIENTO

ANPASSUNG

★N.

F02

02/2009

Rev.
2

ZENNE

Pos.	Code	Q.ty	Description	Notes
58056391	58056391	1	SPRING	
59056365	59056365	1	PTO GEAR	
59056394	59056394	1	DOUBLE GEAR	

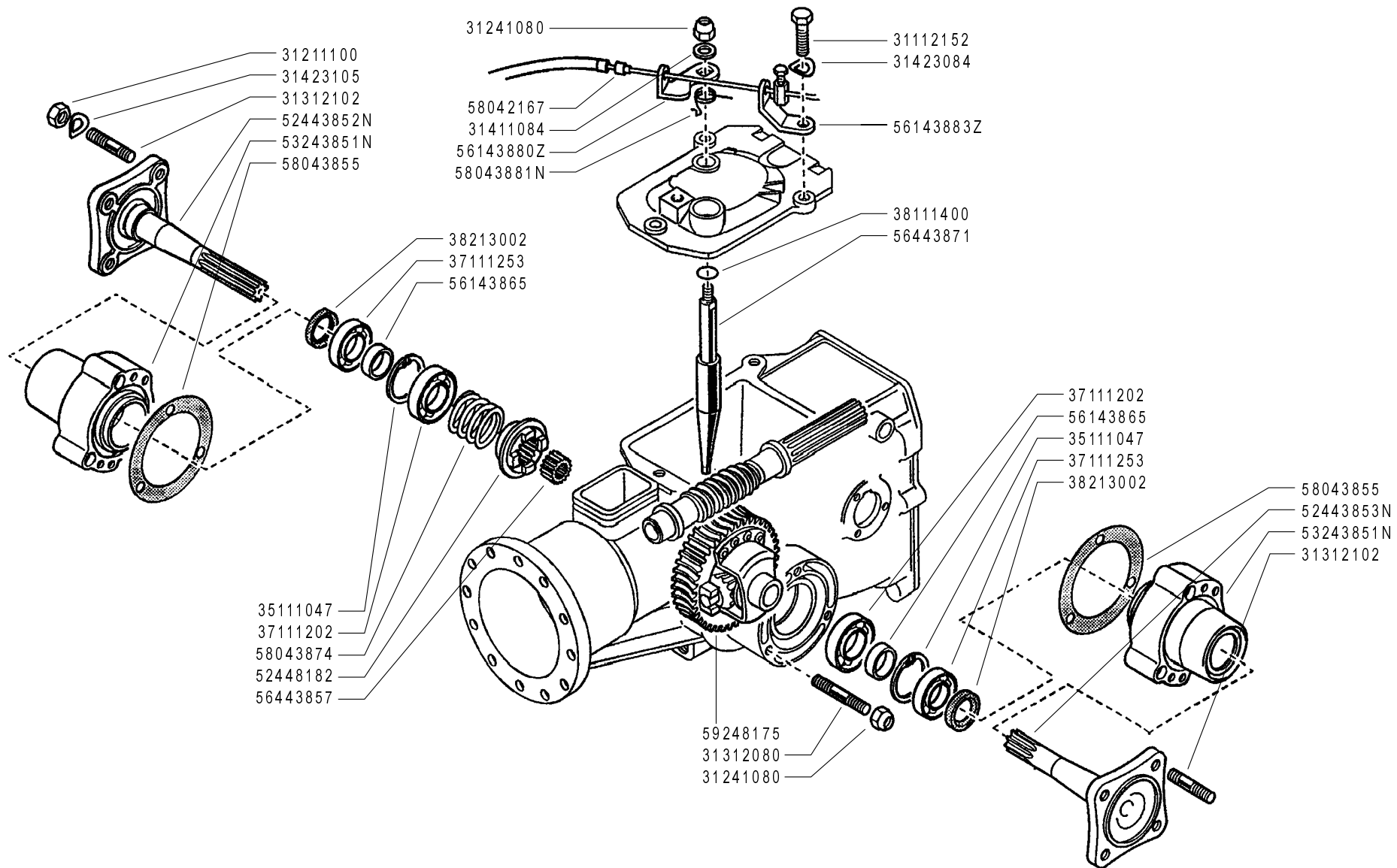

FERRARI

500 serie GRIFON

**DIFFERENZIALE
(515SL GR)**

DIFFERENTIAL
DIFFERENCIAL

DIFFÉRENTIEL
DIFFERENTIAL

DALLA MACCHINA
DE LA MAQUINA
DE LA MACHINE
FROM THE MACHINE
AB DER MASCHINE

N.

G05 0

02/2009

Rev.

0

ZENNE

Pos.	Code	Q.ty	Description	Notes
31112152	31112152	1	SCREW TE M8X30 UNI 5739 8G	
31211100	31211100	1	NUT M10	
31241080	31241080	1	SELFLOCK NUT M8	
31312080	31312080	1	STUD BOLT M8X46X20X12	
31312102	31312102	1	STUD BOLT M10X40X24X12	
31411084	31411084	1	WASHER 8,4x17	
31423084	31423084	1	SPRING WASHER 8,4	
31423105	31423105	1	SPRING WASHER 10,5	
35111047	35111047	1	SEEGER RING I 47 DIN 472	
37111202	37111202	1	BEARING	
37111253	37111253	1	BEARING	
38111400	38111400	1	O-RING 2056 (14,00X1,78)	
38213002	38213002	1	OIL SEAL 30X40X7	
52448182	52448182	1	COUPLING	
56143865	56143865	1	RING	
56443857	56443857	1	SPACER	
56443871	56443871	1	ROD	
58042167	58042167	1	SHEATH TERMINAL	
58043855	58043855	1	GASKET	
58043874	58043874	1	SPRING	
59248175	59248175	1	DIFFERENTIAL GEAR	
52443852	52443852N	1	AXLE SHAFT	
52443853	52443853N	1	AXLE SHAFT	
53243851	53243851N	1	HUB	
56143880	56143880Z	1	SMALL LEVER	
56143883	56143883Z	1	STOP	
58043881	58043881N	1	SPRING	

F02_03 - INGRANAGGI CAMBIO (515L GR-515S GR-515SL GR)

SERIAL START 937702

F.02.02.A0011_03

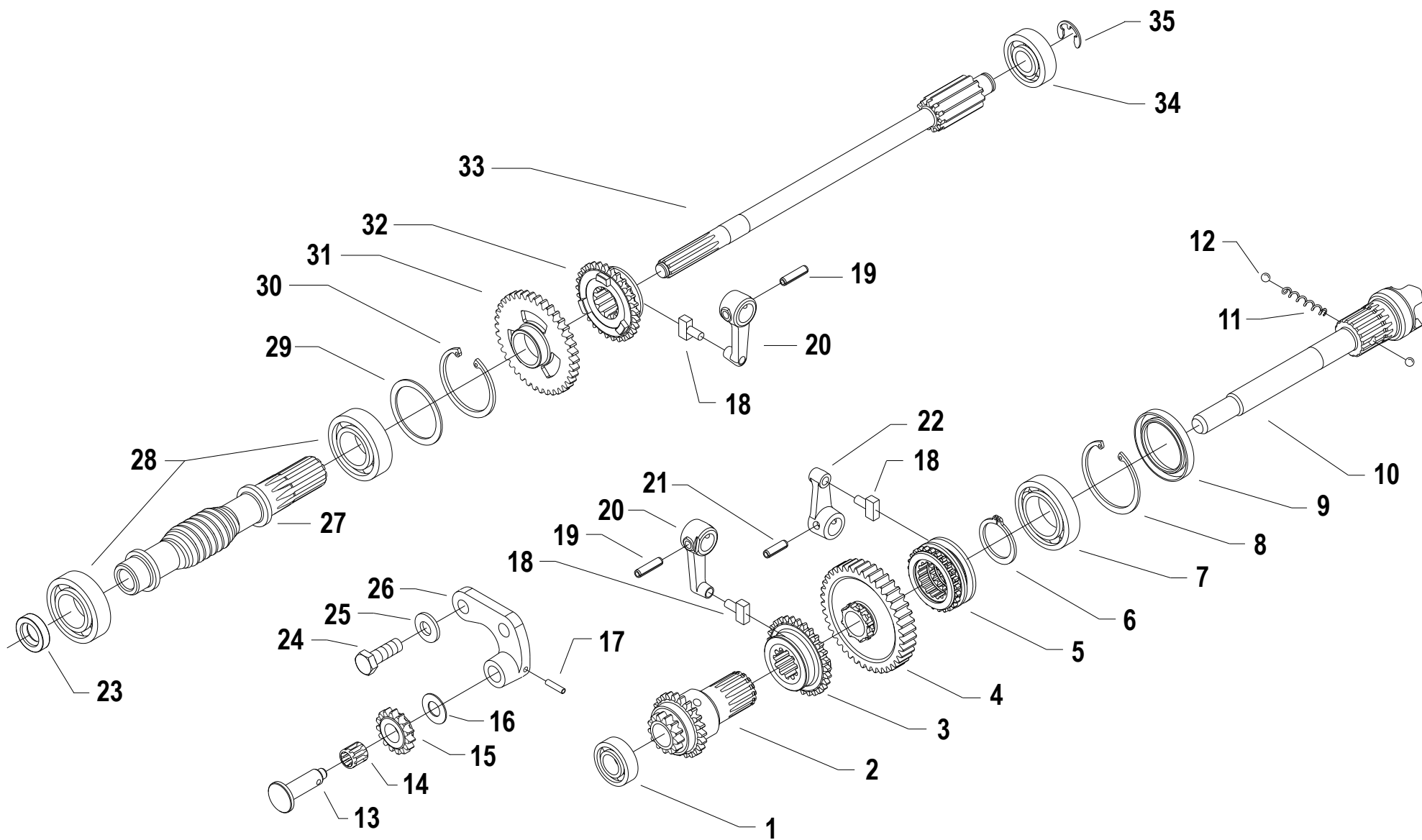

Pos.	Code	Q.ty	Description	Notes
1	37111150		BEARING	
2	59056384		DOUBLE GEAR	
3	52456370		SLIDER	
4	59056707		PTO GEAR	Replaces 59056365 + 52456362
5	52456706		PTO COUPLING	Replaces 59056365 + 52456362
6	35121031		SEEGER RING E 30 UNI 7436	
7	37112229		BEARING	
8	35111055		SEEGER RING I 55 DIN 472	
9	38213800		OIL SEAL 38X55X7	
10	52456335		PTO SHAFT	
11	58056391		SPRING	
12	37910832		BALL 1/4	
13	56456736		PERNO INGRANAGGIO OZIOSO	Replaces 56456351
14	37320120		ROLLER CAGE 12X15/10	
15	56456347		GEAR	
16	56356348		ADJUSTING RING	
17	34211042		ROLL PIN	
18	58043086		SHOE	
19	34213060		ROLL PIN	
20	52456389		LEVER	
21	34213061		ROLL PIN	
22	52456390		LEVER	
23	38211500		OIL SEAL 15X28X7	
24	31112211		SCREW TE M10X30 UNI 5739	
25	31421101		WASHER	
26	52456349		GEAR SUPPORT	
27	56456475		SCREW	
28	37111255		BEARING	
29	56356328		ADJUSTING RING SP=1,5	
29	56356329		ADJUSTING RING SP=1,6	
29	56356330		ADJUSTING RING SP=1,7	
29	56356331		ADJUSTING RING SP=1,8	
30	35111052		SEEGER RING I 52 DIN 472	
31	52456354		GEAR	

SERIAL
START
937702

F02_03 - INGRANAGGI CAMBIO (515L GR-515S GR-515SL GR)

CODE REV
F.02.02.A0011_03

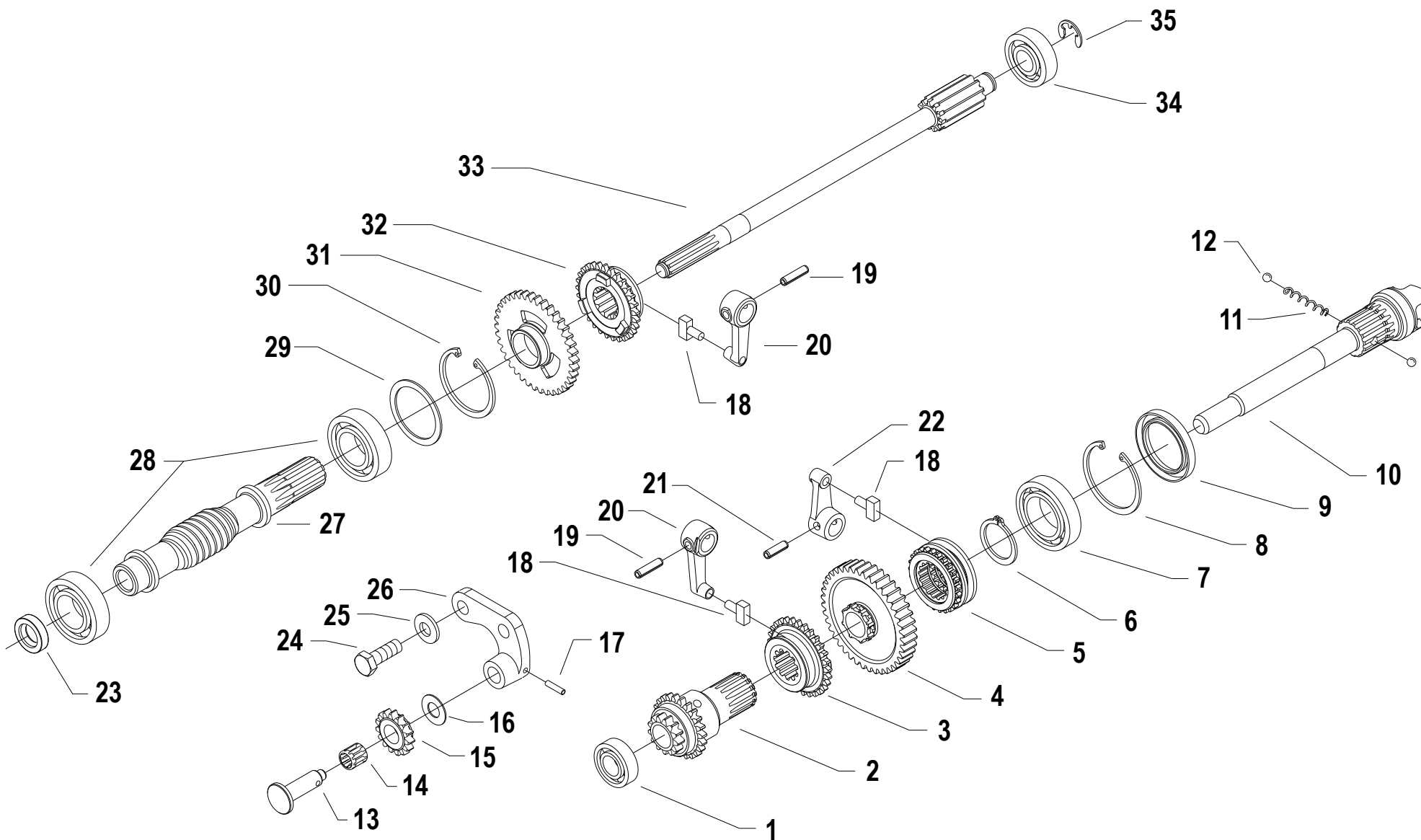

Pos.	Code	Q.ty	Description	Notes
32	52456361		SLIDER	
33	52456339		SHAFT	
34	37111152		BEARING	
35	35211120		SEEGER RING E 12 UNI 7434	

SERIAL
START
937702

F02_03 - INGRANAGGI CAMBIO (515L GR-515S GR-515SL GR)

CODE REV
F.02.02.A0011_03

DIFFERENTIAL

SERIAL START 848877

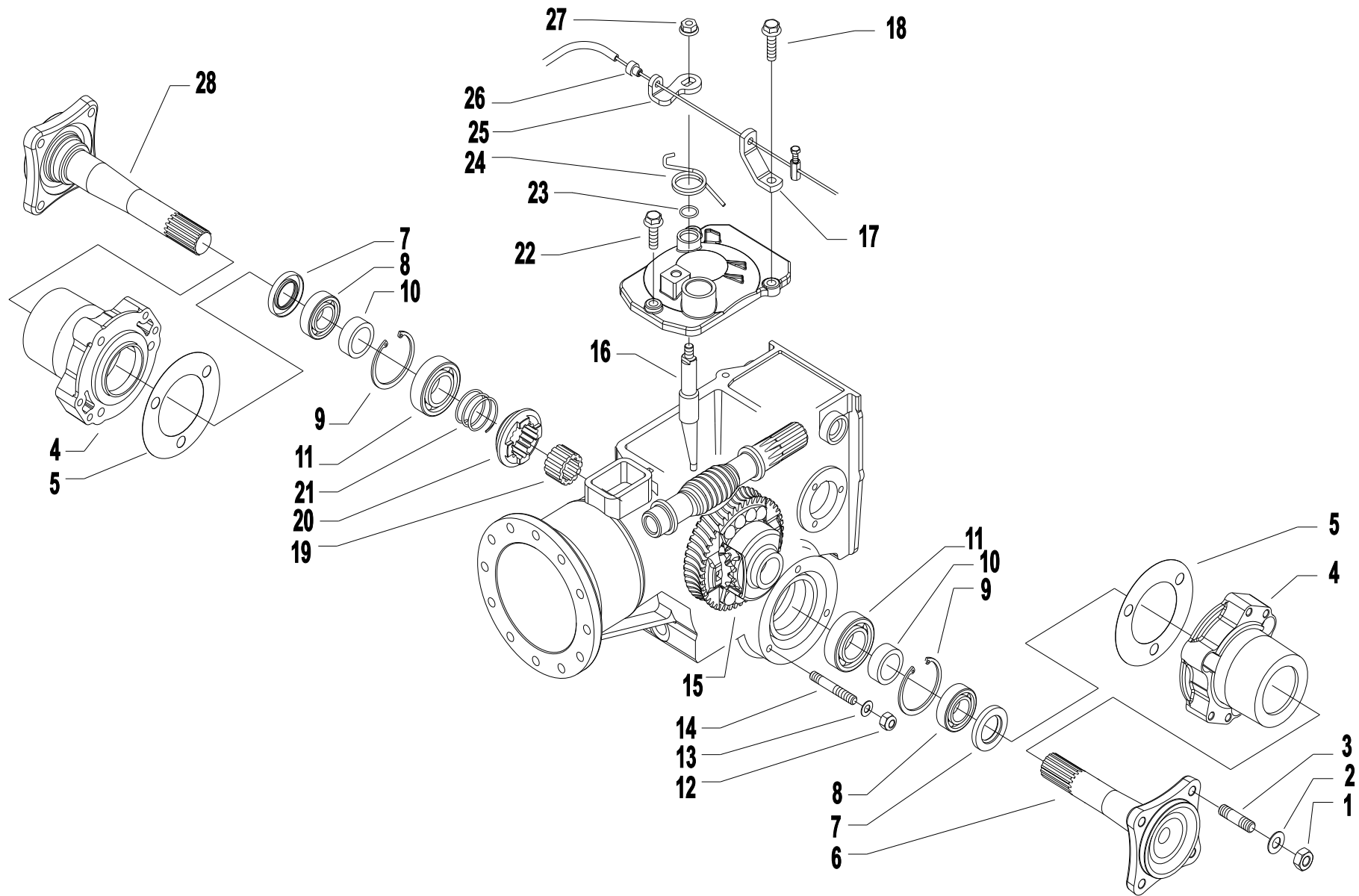

Pos.	Code	Q.ty	Description	Notes
1	31211100	1	NUT M10	
2	31423105	1	SPRING WASHER 10,5	
3	31312102	1	STUD BOLT M10X40X24X12	
4	53243851N	1	HUB	
5	58043855	1	GASKET	
6	52448187	1	AXLE SHAFT	
7	38213002	1	OIL SEAL 30X40X7	
8	37111253	1	BEARING	
9	35111047	1	SEEGER RING I 47 DIN 472	
10	56148184	1	RING	
11	37111250	1	BEARING	
12	31241080	1	SELFLOCK NUT M8	
13	31423084	1	SPRING WASHER 8,4	
14	31312080	1	STUD BOLT M8X46X20X12	
15	59048181	1	DIFFERENTIAL GEAR	
16	56443871	1	ROD	
17	56143883Z	1	STOP	
18	31112167	1	SCREW TE C/F M8X30 DIN 6921 8G	
19	56448183	1	SPACER	
20	56448196	1	COUPLING	
21	58043874	1	SPRING	
22	31112166	1	SCREW TE C/F M8X25 DIN 6921 8G	
23	38111400	1	O-RING 2056 (14,00X1,78)	
24	58043881N	1	SPRING	
25	56143880Z	1	SMALL LEVER	
26	58042167	1	SHEATH TERMINAL	
27	31241084	1	SELFLOCK NUT M8 6S	
28	52448188N	1	AXLE SHAFT	

SERIAL
START
848877

DIFFERENTIAL

CODE REV
G.05.02.A0011_01

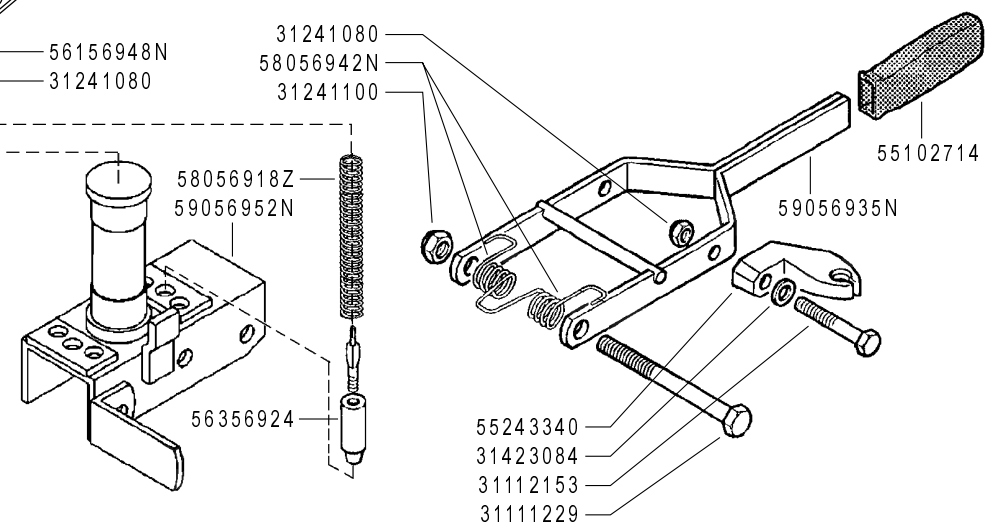
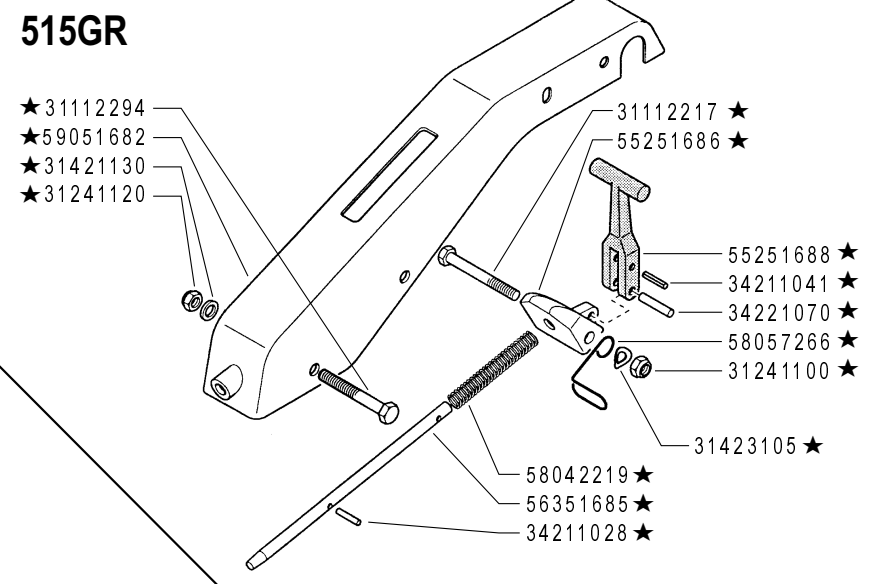
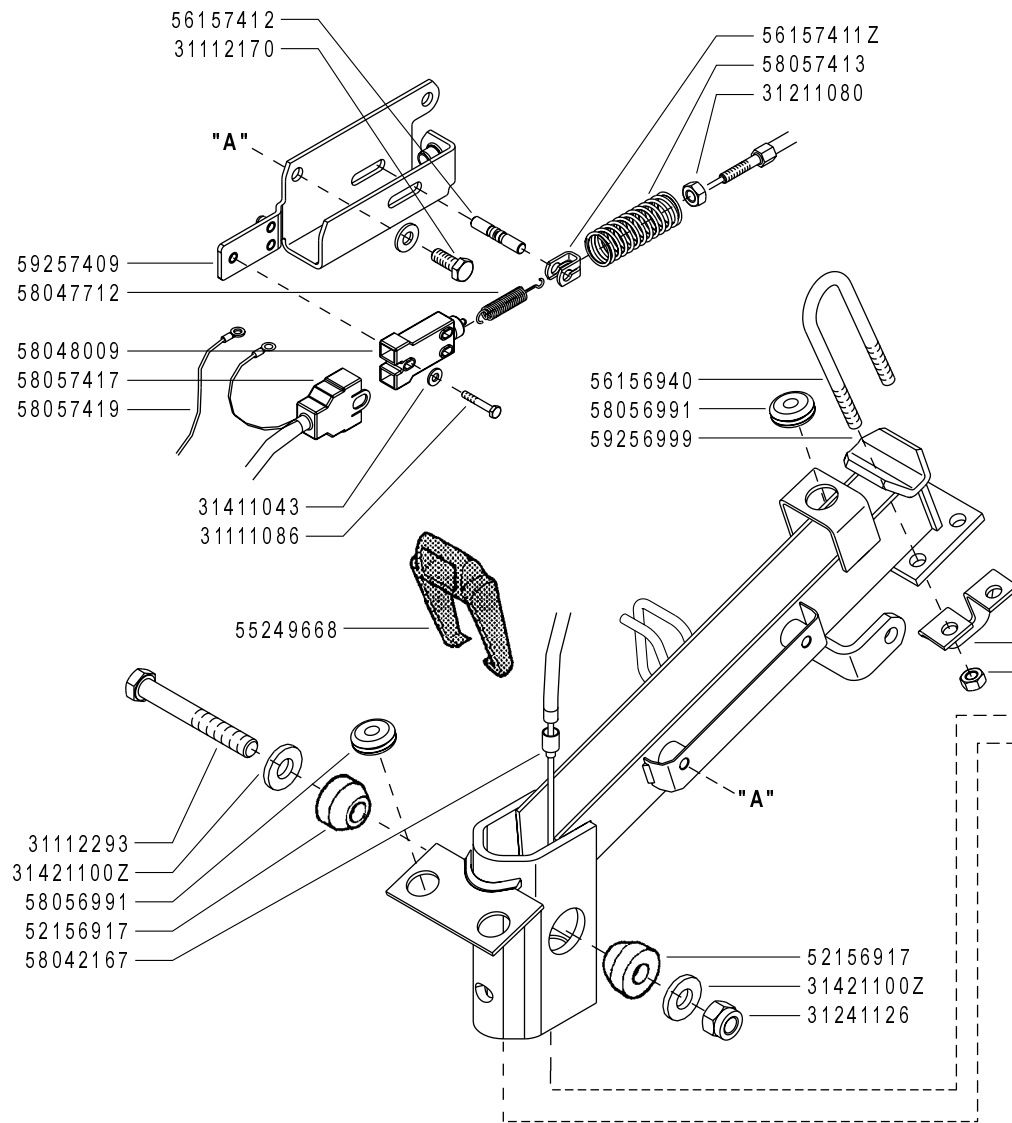

	500 serie GRIFON	PIANTONE (515GR - 515L GR - 515S GR - 515SL GR ★)		DALLA MACCHINA DE LA MAQUINA FROM THE MACHINE AB DER MASCHINE	ERRATA CORRIGE	Rev. H01 2
		STEERING COLUMN COLUMNNA	PLANTON LENKSÄULE		★N.	

Pos.	Code	Q.ty	Description	Notes
31111086	31111086	1	SCREW TE M4X25 UNI 5739 8G	
31111229	31111229	1	SCREW TE M10X110 UNI 5737 8G	
31112153	31112153	1	SCREW TE M8X35 UNI 5739 8G	
31112170	31112170	1	SCREW TE C/F M8X20 DIN 6921	
31112217	31112217	1	SCREW TE M10X80 UNI 5737	
31112293	31112293	1	SCREW TE M12X80 UNI 5737	
31112294	31112294	1	SCREW TE M12X85 UNI 5737	
31211080	31211080	1	NUT M8	
31241080	31241080	1	SELFLOCK NUT M8	
31241100	31241100	1	SELFLOCK NUT M10 6S	
31241120	31241120	1	SELFLOCK NUT M12	
31241126	31241126	1	SELFLOCK NUT M12	
31411043	31411043	1	WASHER 4,3X9	
31421130	31421130	1	WASHER	
31423084	31423084	1	SPRING WASHER 8,4	
31423105	31423105	1	SPRING WASHER 10,5	
34211028	34211028	1	ROLL PIN	
34211041	34211041	1	ROLL PIN	
34221070	34221070	1	CYLINDRICAL PLUG 8X50 UNI 1707	
52156917	52156917	1	WEDGE	
55102714	55102714	1	KNOB	
55243340	55243340	1	SUPPORT	
55249668	55249668	1	PASSING	
55251686	55251686	1	LEVER BEARING	
55251688	55251688	1	LEVER	
56156940	56156940	1	U BOLT	
56157412	56157412	1	PIN	
56351685	56351685	1	ROD	
56356924	56356924	1	FERRULE	
58042167	58042167	1	SHEATH TERMINAL	
58042219	58042219	1	SPRING	
58047712	58047712	1	SPRING	
58048009	58048009	1	SWITCH	
58056991	58056991	1	CABLE GLAND	

SERIAL
START
825532

STEERING COLUMN

Version: 515GR, 515L GR, 515S GR, 515SL GR

CODE REV

H01_2_67804

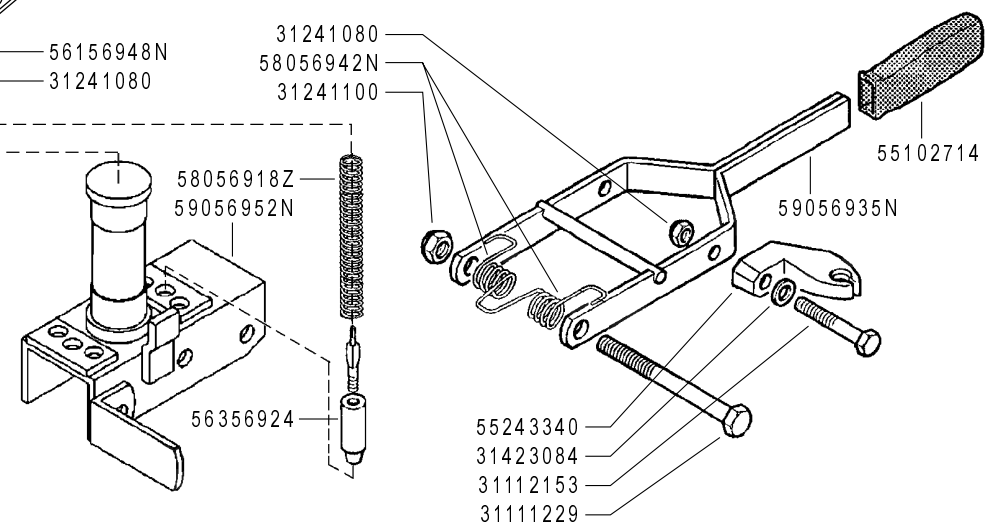
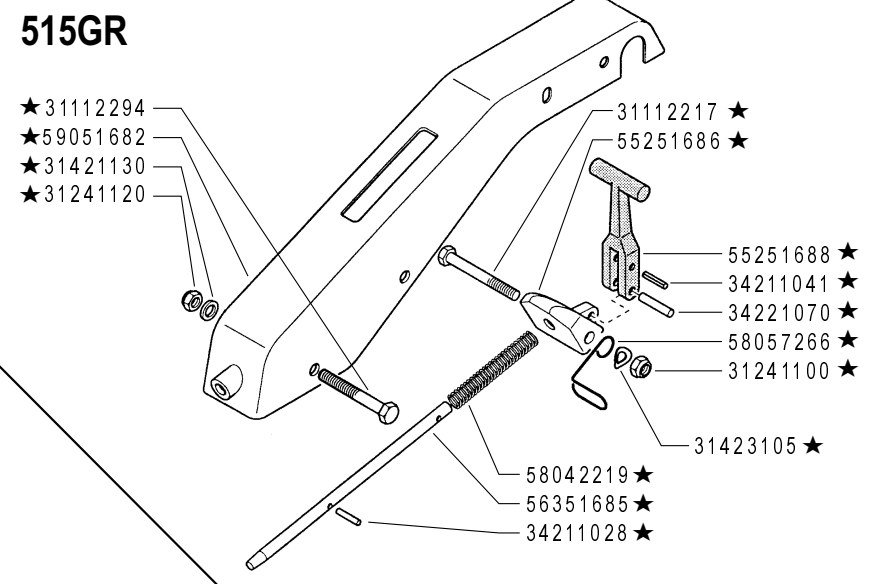
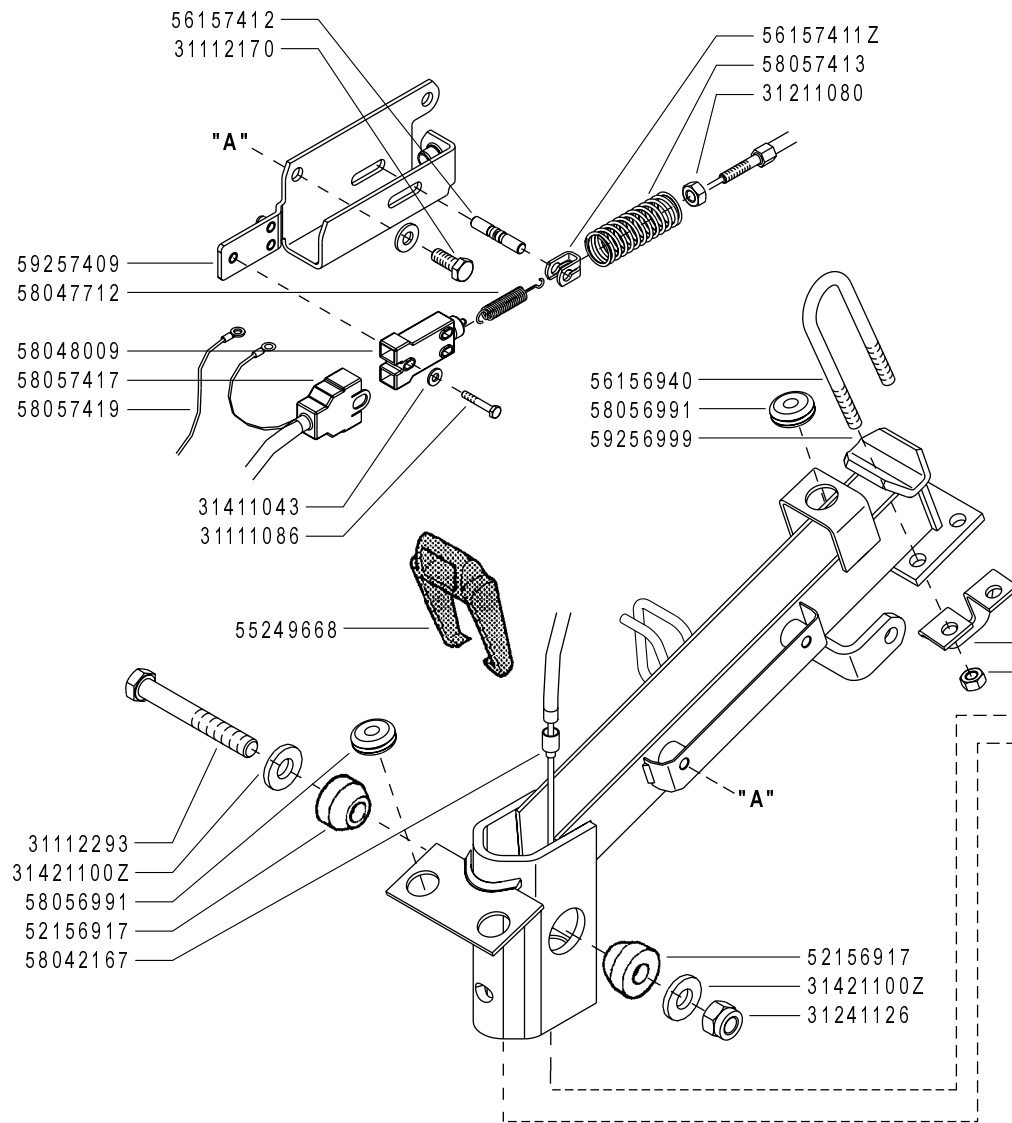

FERRARI 500 serie GRIFON

PIANTONE
(515GR - 515L GR - 515S GR - 515SL GR ★)

STEERING COLUMN
COLUMNNA

PLANTON
LENKSÄULE

DALLA MACCHINA
DE LA MAQUINA
DE LA MACHINE
FROM THE MACHINE
AB DER MASCHINE

★N.

ERRATA CORRIGE
825532 (515GR)

Rev. **H01** 2

02/2009

Pos.	Code	Q.ty	Description	Notes
58057266	58057266	1	HOLDER	
58057413	58057413	1	RETAINING SPRING	
58057417	58057417	1	WIRING	
58057419	58057419	1	WIRING	
59051682	59051682	1	HANDLE BAR COLUMN	
59256999	59256999	1	COLUMN	
59257409	59257409	1	SUPPORT	
31421100	31421100Z	1	CUP SPRING	
56156948	56156948N	1	STOP	
56157411	56157411Z	1	FORK	
58056918	58056918Z	1	SPRING	
58056942	58056942N	1	SPRING	
59056935	59056935N	1	LEVER	
59056952	59056952N	1	SUPPORT	

SERIAL
START
825532

STEERING COLUMN

Version: 515GR, 515L GR, 515S GR, 515SL GR

CODE REV

H01_2_67804

STEERING COLUMN

SERIAL START 863996

H.01.02.A0011_03

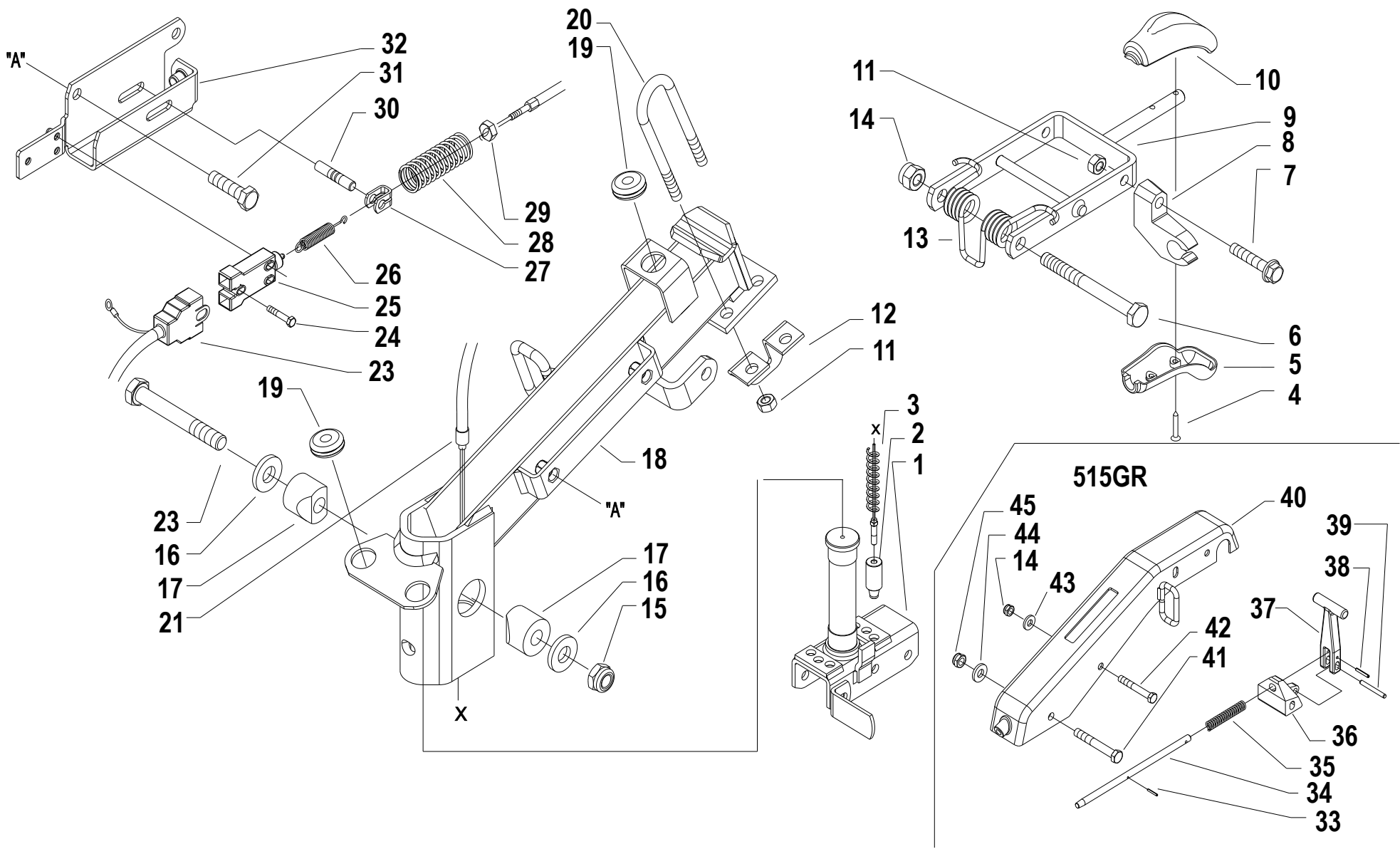

Pos.	Code	Q.ty	Description	Notes
1	59056952N	1	SUPPORT	
2	56356924	1	FERRULE	
3	58056918Z	1	SPRING	
4	31100451	1	SCREW 3,5X25	
5	55157213	1	GRIP	
6	31111229	1	SCREW TE M10X110 UNI 5737 8G	
7	31112165	1	SCREW TE C/F M8X35 DIN 6921 8G	
8	55243340	1	SUPPORT	
9	59057010N	1	LEVER	
10	55157212	1	GRIP	
11	31241080	1	SELFLOCK NUT M8	
12	56156948N	1	STOP	
13	58056942N	1	SPRING	
14	31241100	1	SELFLOCK NUT M10 6S	
15	31241126	1	SELFLOCK NUT M12	
16	31421100Z	1	CUP SPRING	
17	52156917	1	WEDGE	
18	59256999	1	COLUMN	
19	58056991	1	CABLE GLAND	
20	56156940	1	U BOLT	
21	58042167	1	SHEATH TERMINAL	
22	31112293	1	SCREW TE M12X80 UNI 5737	
23	58057417	1	WIRING	
24	31121024	1	SCREW TBCEI FL.M4X25	
25	58048009	1	SWITCH	
26	58047712	1	SPRING	
27	56157411Z	1	FORK	
28	58057413	1	RETAINING SPRING	
29	31211080	1	NUT M8	
30	56157412	1	PIN	
31	31112170	1	SCREW TE C/F M8X20 DIN 6921	
32	59257409	1	SUPPORT	
33	34211028	1	ROLL PIN	
34	56351685Z	1	ROD	

SERIAL
START
863996

STEERING COLUMN

CODE REV

H.01.02.A0011_03

STEERING COLUMN

SERIAL START 863996

H.01.02.A0011_03

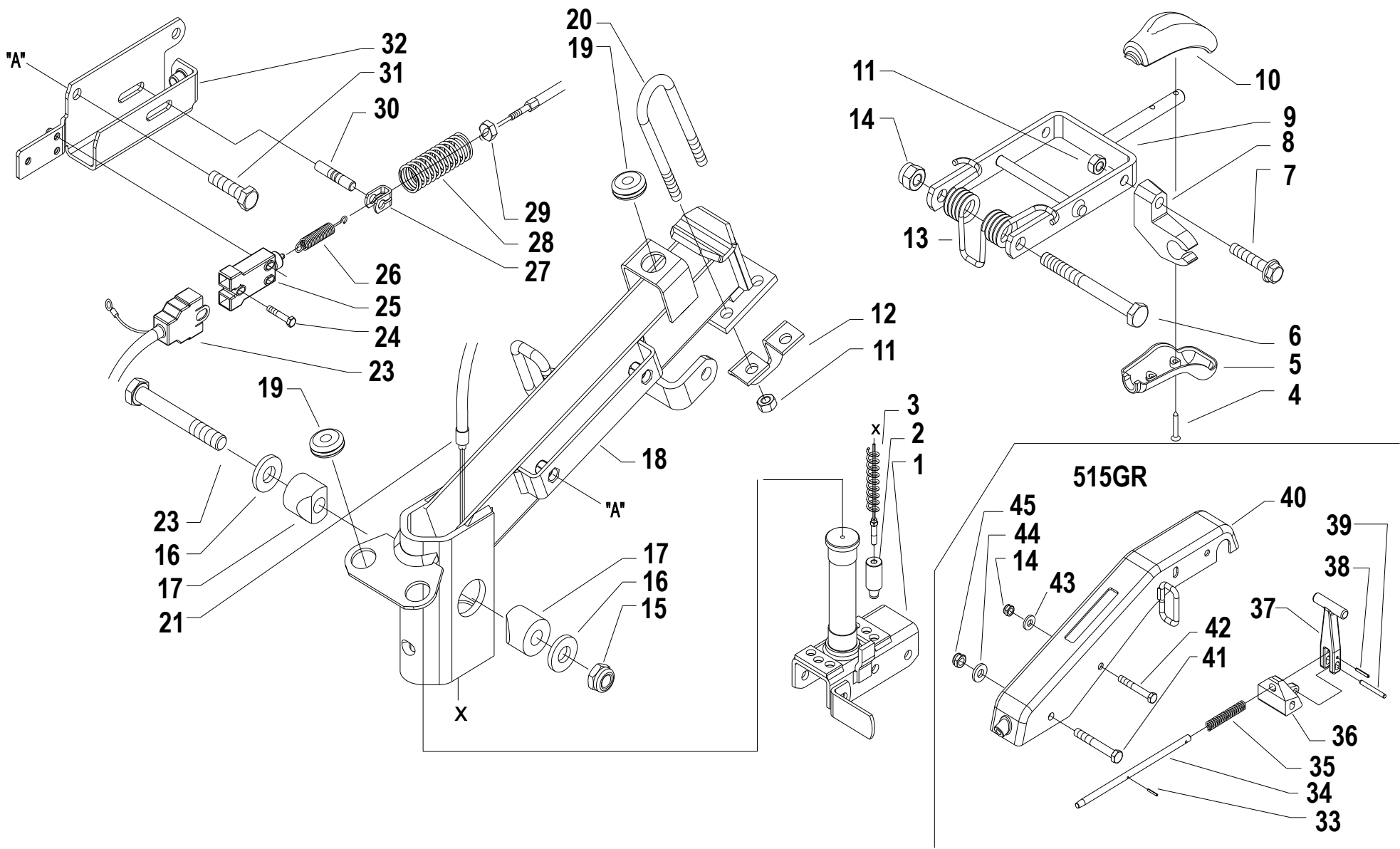

Pos.	Code	Q.ty	Description	Notes
35	58042219	1	SPRING	
36	55251686	1	LEVER BEARING	
37	55251688	1	LEVER	
38	34211041	1	ROLL PIN	
39	34221070	1	CYLINDRICAL PLUG 8X50 UNI 1707	
40	59056817V	1	COLUMN	
41	31112294	1	SCREW TE M12X85 UNI 5737	
42	31112217	1	SCREW TE M10X80 UNI 5737	
43	31423105	1	SPRING WASHER 10,5	
44	31421130	1	WASHER	
45	31241120	1	SELFLOCK NUT M12	

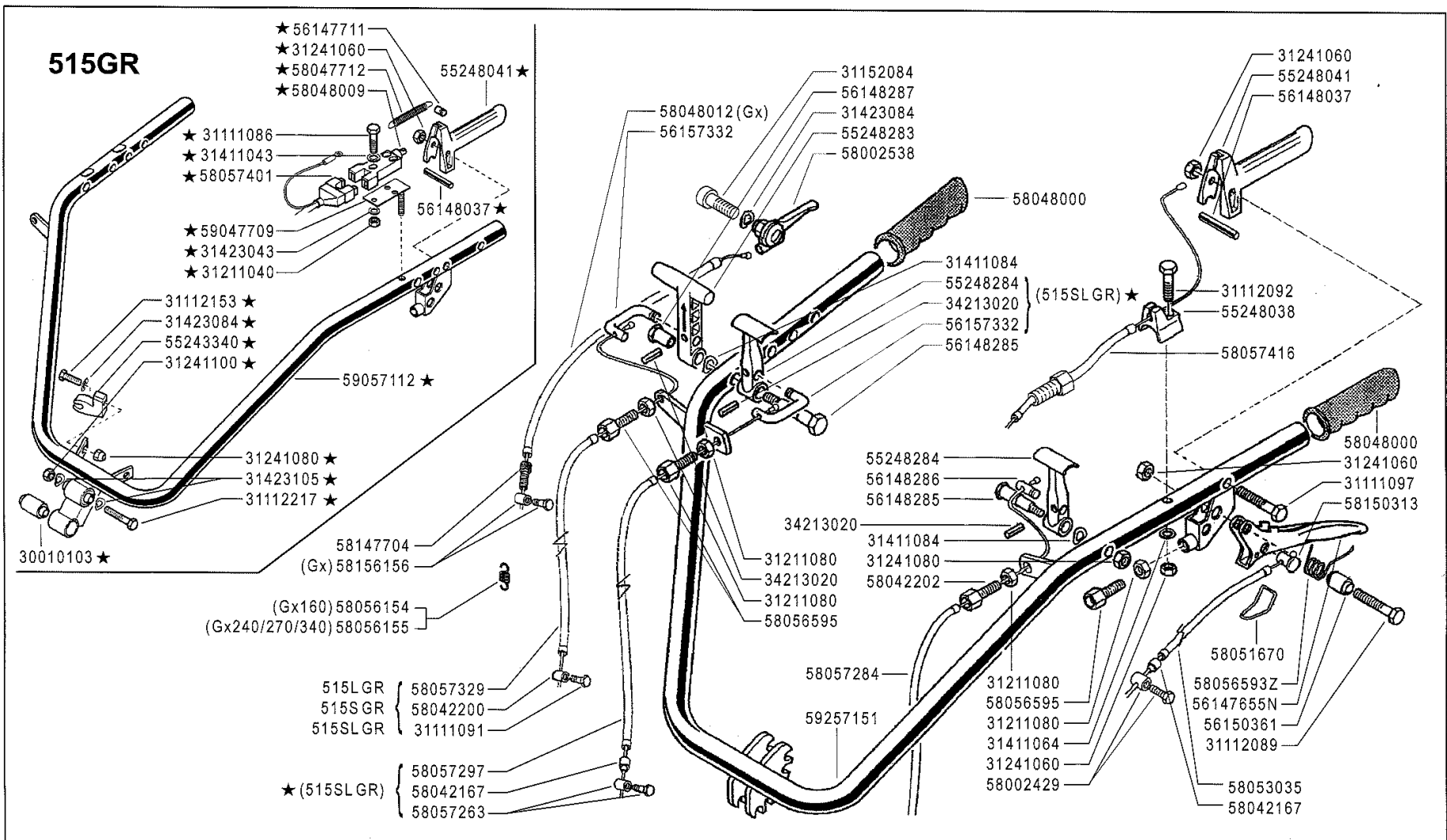

FERRARI

500 serie **GRIFON**

MANUBRIO
(515GR - 515LGR - 515SGR - 515SLGR ★)

ENGINE GUARDS
PROTECCIONES MOTOR

PROTECTIONS MOTEUR
MOTOR SCHUTZ

DALLA MACCHINA
DE LA MAQUINA
DE LA MACHINE
FROM THE MACHINE
AB DER MASCHINE

ERRATA CORRIGE

825532 (515GR)

I01 **2**

02/2009

★ N.

ZENNE

Pos.	Code	Q.ty	Description	Notes
30010103	30010103	1	SILENT-BLOCK 10,2X30X45X60,5	
31111086	31111086	1	SCREW TE M4X25 UNI 5739 8G	
31111091	31111091	1	SCREW E M6X14 UNI 5739 8G	
31111097	31111097	1	SCREW TE M6X45 UNI 5737 8G	
31112089	31112089	1	SCREW TE M6X25 UNI 5739 8G	
31112092	31112092	1	SCREW TE M6X35 UNI 5739 8G	
31112153	31112153	1	SCREW TE M8X35 UNI 5739 8G	
31112217	31112217	1	SCREW TE M10X80 UNI 5737	
31152084	31152084	1	SCREW TCEI M8X35 UNI 5931	
31211040	31211040	1	NUT M4	
31211080	31211080	1	NUT M8	
31241060	31241060	1	SELFLOCK NUT M6	
31241080	31241080	1	SELFLOCK NUT M8	
31241100	31241100	1	SELFLOCK NUT M10 6S	
31411043	31411043	1	WASHER 4,3X9	
31411064	31411064	1	WASHER 6,4x12,5	
31411084	31411084	1	WASHER 8,4x17	
31423043	31423043	1	SPRING WASHER 4,3	
31423084	31423084	1	SPRING WASHER 8,4	
31423105	31423105	1	SPRING WASHER 10,5	
34213020	34213020	1	ROLL PIN	
55243340	55243340	1	SUPPORT	
55248038	55248038	1	STOP	
55248041	55248041	1	LEVER	
55248283	55248283	1	COMMAND LEVER	
55248284	55248284	1	LEVER	
56147711	56147711	1	PIN	
56148037	56148037	1	LEVER STOP	
56148285	56148285	1	PIN	
56148286	56148286	1	PIN	
56150361	56150361	1	SPACER	
56157332	56157332	1	U BOLT	
58002429	58002429	1	CLAMPING SCREW	
58042167	58042167	1	SHEATH TERMINAL	

SERIAL
START
825532

HANDLEBAR

Version: 515GR, 515L GR, 515S GR, 515SL GR

CODE REV

I01_2_67839

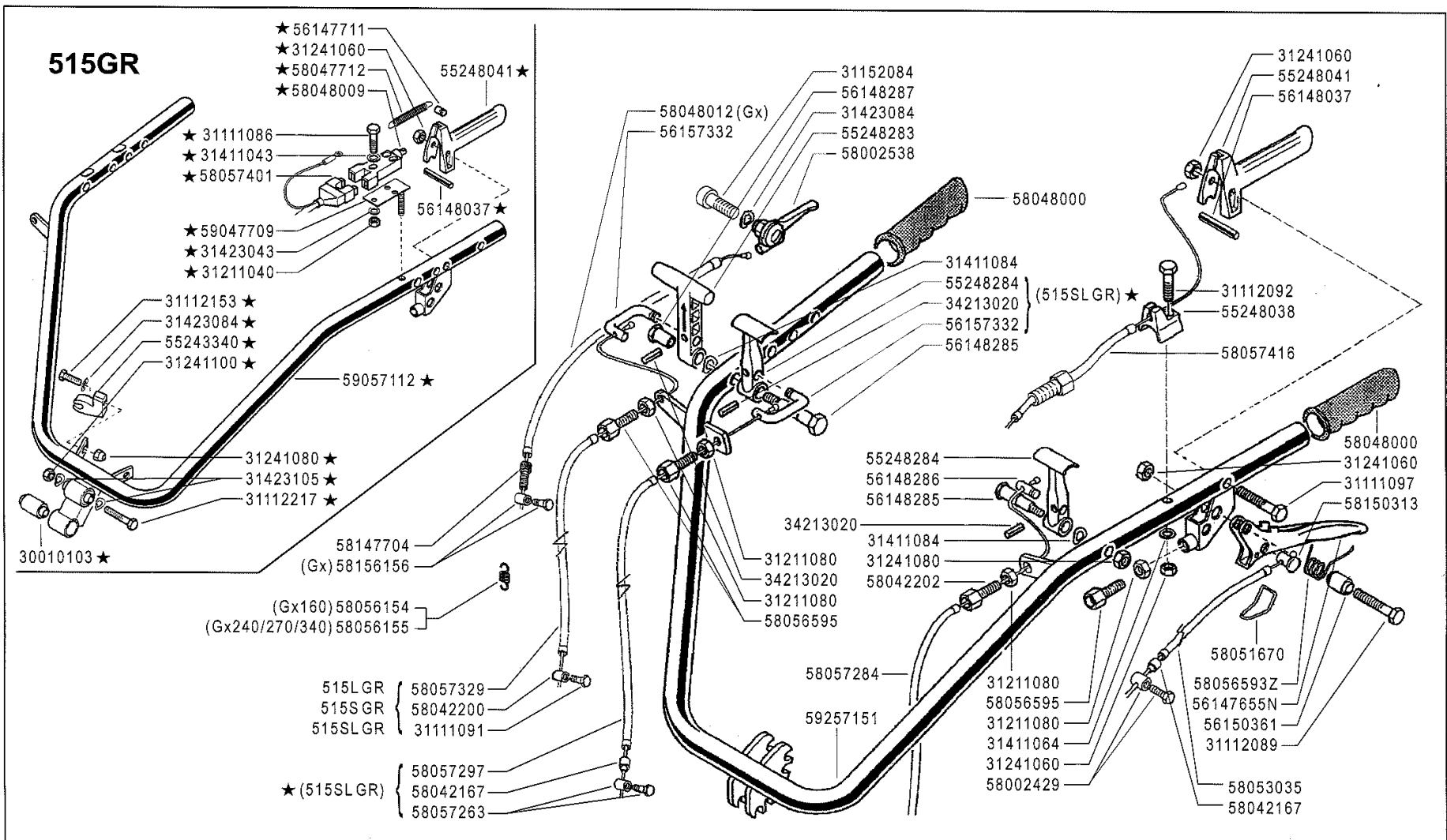

FERRARI

500 serie **GRIFON**

MANUBRIO
(515GR - 515LGR - 515SGR - 515SLGR ★)

ENGINE GUARDS
PROTECCIONES MOTOR

PROTECTIONS MOTEUR
MOTOR SCHUTZ

DALLA MACCHINA
DE LA MAQUINA
DE LA MACHINE
FROM THE MACHINE
AB DER MASCHINE

ERRATA CORRIGE

I01 **2**

★ N.

825532 (515GR)

02/2009

ZENNE

Pos.	Code	Q.ty	Description	Notes
58042200	58042200	1	CLAMPING SCREW	
58042202	58042202	1	ADJUSTING SCREW	
58047712	58047712	1	SPRING	
58048000	58048000	1	KNOB	
58048009	58048009	1	SWITCH	
58048012	58048012	1	LINE AND SHEATH	
58051670	58051670	1	CLEVIS	
58053035	58053035	1	LINE AND SHEATH	
58056154	58056154	1	RESTORING SPRING	Utilizzato con motore GX200
58056155	58056155	1	RESTORING SPRING	Utilizzato con motore GX270
58056158	58056158	1	COUPLING	
58056164	58056164	1	RESTORING SPRING	
58056595	58056595	1	ADJUSTING SCREW	
58057263	58057263	1	CLAMPING SCREW	
58057284	58057284	1	LINE AND SHEATH	
58057297	58057297	1	LINE AND SHEATH	
58057329	58057329	1	LINE AND SHEATH	
58057401	58057401	1	WIRING	
58057416	58057416	1	LINE AND SHEATH	
58147704	58147704	1	ADJUSTING SCREW	
58150313	58150313	1	CABLE CLAMP	
58156156	58156156	1	TERMINAL	
59047709	59047709	1	SWITCH SUPPORT	
59057112	59057112	1	COMPLETE HANDLE BAR	
59257151	59257151	1	COMPLETE HANDLE BAR	
56147655	56147655N	1	CLUTCH LEVER	
58056593	58056593Z	1	SPRING	

SERIAL
START
825532

HANDLEBAR

Version: 515GR, 515L GR, 515S GR, 515SL GR

CODE REV

I01_2_67839

HANDLEBAR

SERIAL START 863996

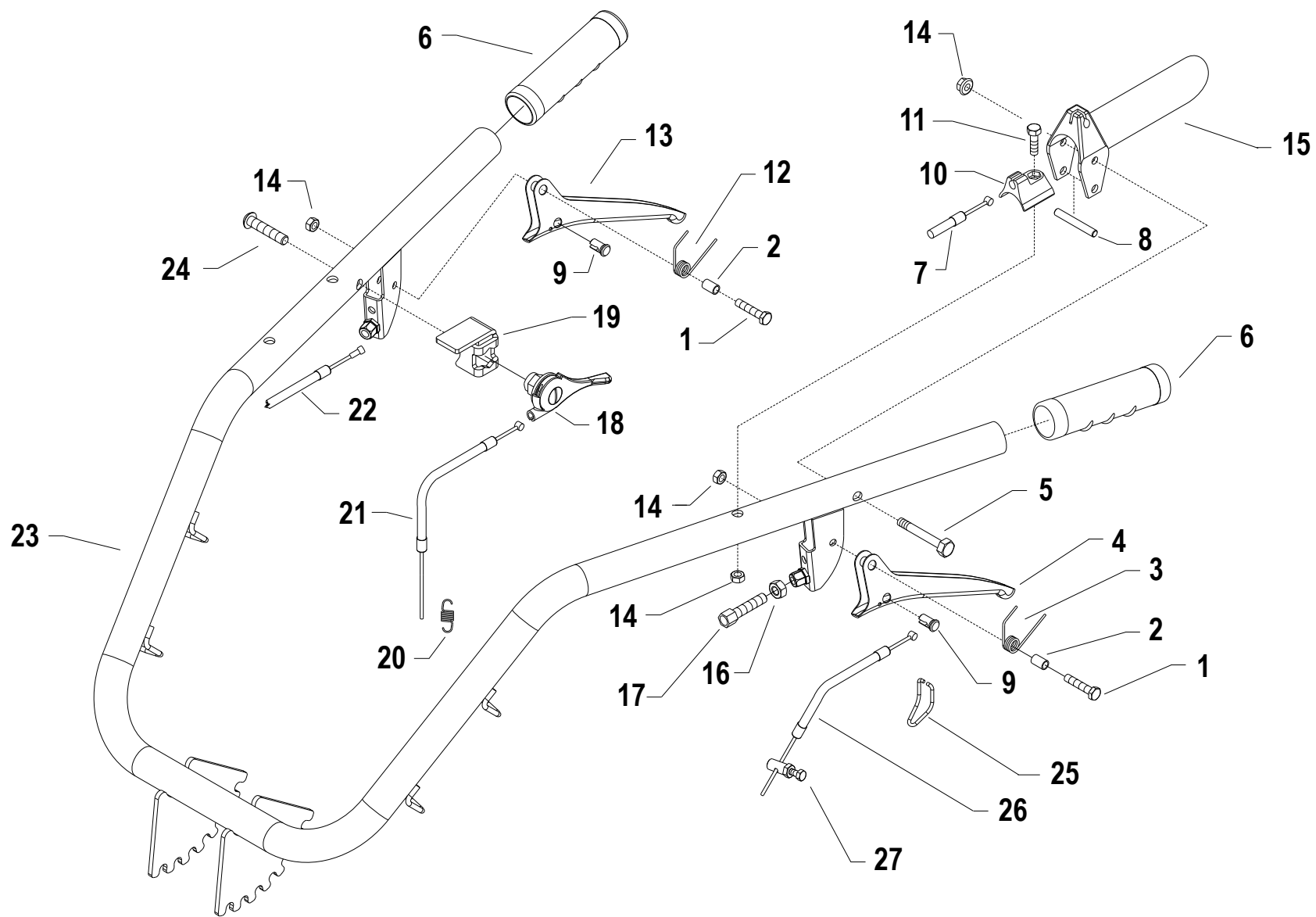

Pos.	Code	Q.ty	Description	Notes
1	31112089	1	SCREW TE M6X25 UNI 5739 8G	
2	56156603Z	1	SPACER	
3	58050345	1	SPRING	
4	56147655N	1	CLUTCH LEVER	
5	31111097	1	SCREW TE M6X45 UNI 5737 8G	
6	58048000	1	KNOB	
7	58048355	1	LINE AND SHEATH	For diesel engines
7	58057418	1	LINE AND SHEATH	
8	56148037	1	LEVER STOP	
9	58150313	1	CABLE CLAMP	
10	55248038	1	STOP	
11	31112092	1	SCREW TE M6X35 UNI 5739 8G	
12	58056593	1	SPRING	
13	56148470N	1	LEVER	
14	31241060	1	SELFLOCK NUT M6	
15	55248041	1	LEVER	
16	31211080	1	NUT M8	
17	58056595	1	ADJUSTING SCREW	
18	58002538	1	COMMAND LEVER	
19	56156874N	1	PANEL	
20	58056154	1	RESTORING SPRING	Utilizzato con motore GX200 - For motors GX200
20	58056155	1	RESTORING SPRING	Utilizzato con motore GX270 - For the engine GX270
21	58056815	1	LINE AND SHEATH	For motors GX200/GX270
22	58056193	1	TRASMISSIONE SBLOCC.PIANTONE	
23	59257162	1	MANUBRIO MC USA C/CORTO C/P.I.	
24	31121020	1	VITE TBCEI M8X40 ISO7380 10K	

SERIAL
START
863996

HANDLEBAR

CODE REV
I.01.02.A0011_03

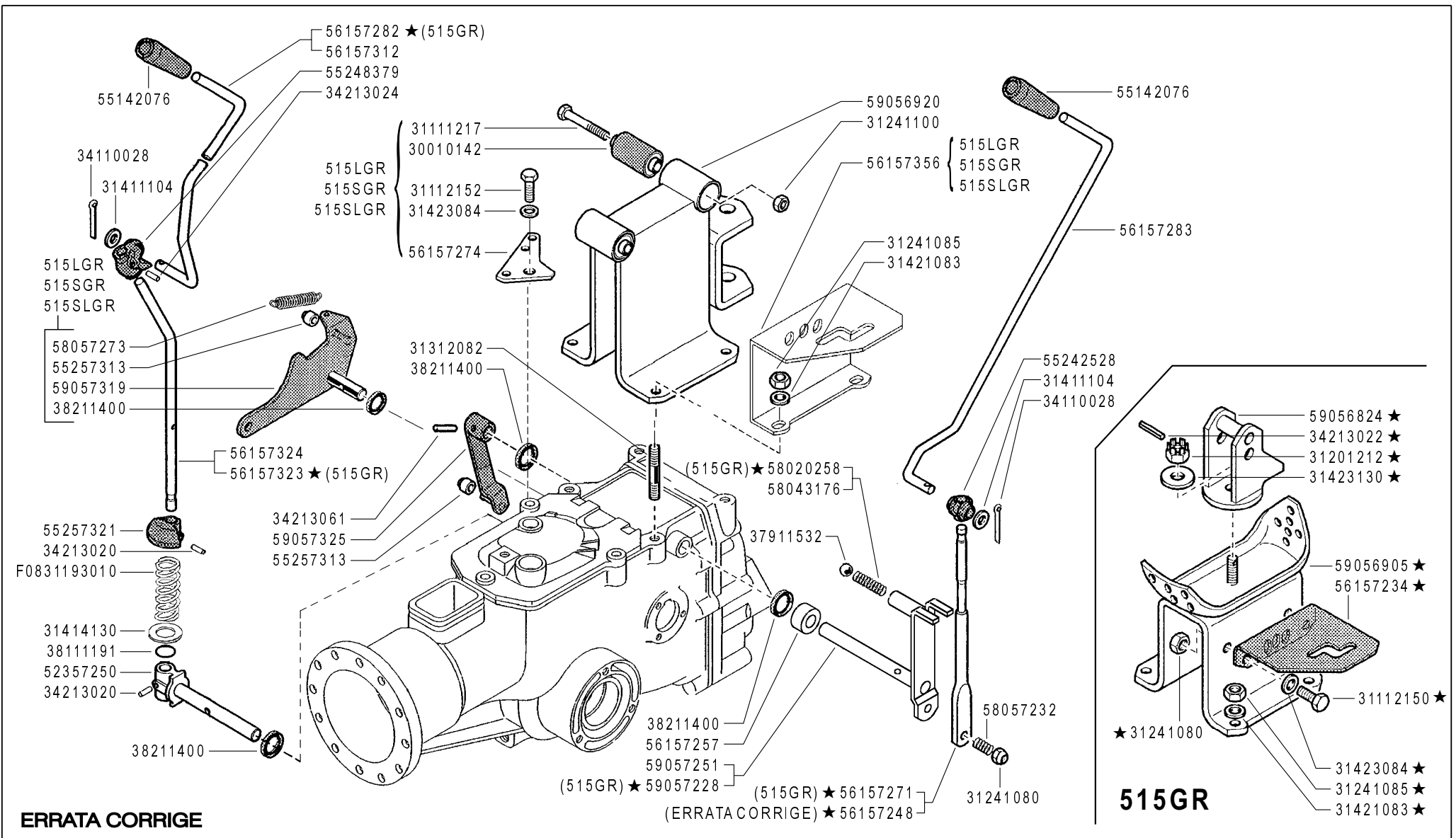

ERRATA CORRIGE

	500 serie GRIFON	COMANDI (515GR - 515L GR - 515S GR - 515SL GR ★)		DALLA MACCHINA DE LA MAQUINA DE LA MACHINE FROM THE MACHINE AB DER MASCHINE	Rev.	
		CONTROLS MANDOS	COMMANDES ANTRIEBE		J01	1
				★N.	825532 (515GR)	02/2009

Pos.	Code	Q.ty	Description	Notes
30010142	30010142	1	SILENT-BLOCK 10,2X30X45X49	
31111217	31111217	1	SCREW TE M10X75 UNI 5737 8G	
31112150	31112150	1	SCREW TE M8X20 UNI 5739 8G	
31112152	31112152	1	SCREW TE M8X30 UNI 5739 8G	
31201212	31201212	1	NUT M12	
31241080	31241080	1	SELFLOCK NUT M8	
31241085	31241085	1	SELFLOCK NUT M8 6S	
31241100	31241100	1	SELFLOCK NUT M10 6S	
31312082	31312082	1	STUD BOLT M8X38X14X20	
31411104	31411104	1	WASHER 10,5x18	
31414130	31414130	1	WASHER 13	
31421083	31421083	1	WASHER	
31423084	31423084	1	SPRING WASHER 8,4	
31423130	31423130	1	SPRING WASHER 13	
34110028	34110028	1	SPLIT PIN	
34213020	34213020	1	ROLL PIN	
34213022	34213022	1	ROLL PIN	
34213024	34213024	1	ROLL PIN	
34213061	34213061	1	ROLL PIN	
37911532	37911532	1	BALL 15/32	
38111191	38111191	1	O-RING 115 (11,91X2,62)	
38111400	38111400	1	O-RING 2056 (14,00X1,78)	
38211400	38211400	1	OIL SEAL 14X22X4	
52357250	52357250	1	PIN	
55142076	55142076	1	KNOB	
55242528	55242528	1	JOINT	
55248379	55248379	1	JOINT	
55257313	55257313	1	ROLLER	
55257321	55257321	1	STOP	
56157234	56157234	1	GEAR SELECTOR	
56157248	56157248	1	COMMAND LEVER	
56157257	56157257	1	SPACER	
56157271	56157271	1	COMMAND LEVER	
56157274	56157274	1	SQUARE	

SERIAL
START
825532

CONTROLS

Version: 515GR, 515L GR, 515S GR, 515SL GR

CODE REV

J01_1_67885

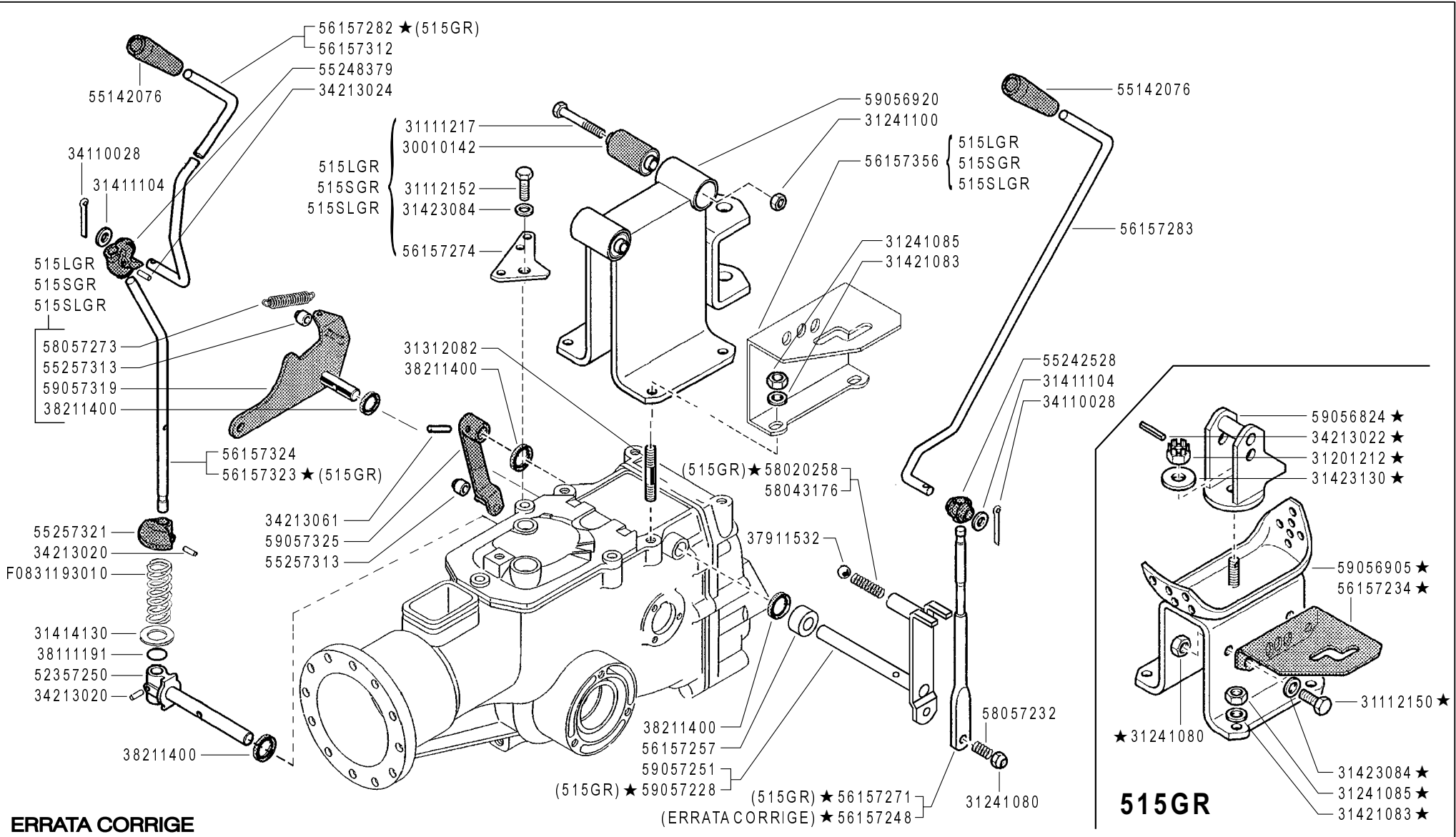

ERRATA CORRIGE

FERRARI

500 serie GRIFON

COMANDI
 (515GR - 515L GR - 515S GR - 515SL GR ★)

CONTROLS
 MANDOS

COMMANDES
 ANTRIEBE

DALLA MACCHINA
 DE LA MAQUINA
 DE LA MACHINE
 FROM THE MACHINE
 AB DER MASCHINE

★N.

825532 (515GR)

J01

02/2009

Rev.

1

ZENNE

Pos.	Code	Q.ty	Description	Notes
56157282	56157282	1	ROD	
56157283	56157283	1	GEARSHIFT ROD	
56157312	56157312	1	ROD	
56157323	56157323	1	PTO LEVER	
56157324	56157324	1	PTO LEVER	
56157349	56157349	1	SELECTOR	
56157356	56157356	1	GEAR SELECTOR	
58020258	58020258	1	SPRING	
58043176	58043176	1	SPRING	
58057232	58057232	1	SPRING	
58057273	58057273	1	SPRING	
59056824	59056824	1	SUPPORTO PIANTONE 710 PS	
59056905	59056905	1	SUMP	
59056920	59056920	1	SUPPORT	
59057228	59057228	1	GEAR LEVER	
59057251	59057251	1	GEAR LEVER	
59057319	59057319	1	LEVER	
59057325	59057325	1	LEVER	
F0831193	F0831193010	1	SPRING DM.15X70	

SERIAL
START
825532

CONTROLS

Version: 515GR, 515L GR, 515S GR, 515SL GR

CODE REV

J01_1_67885

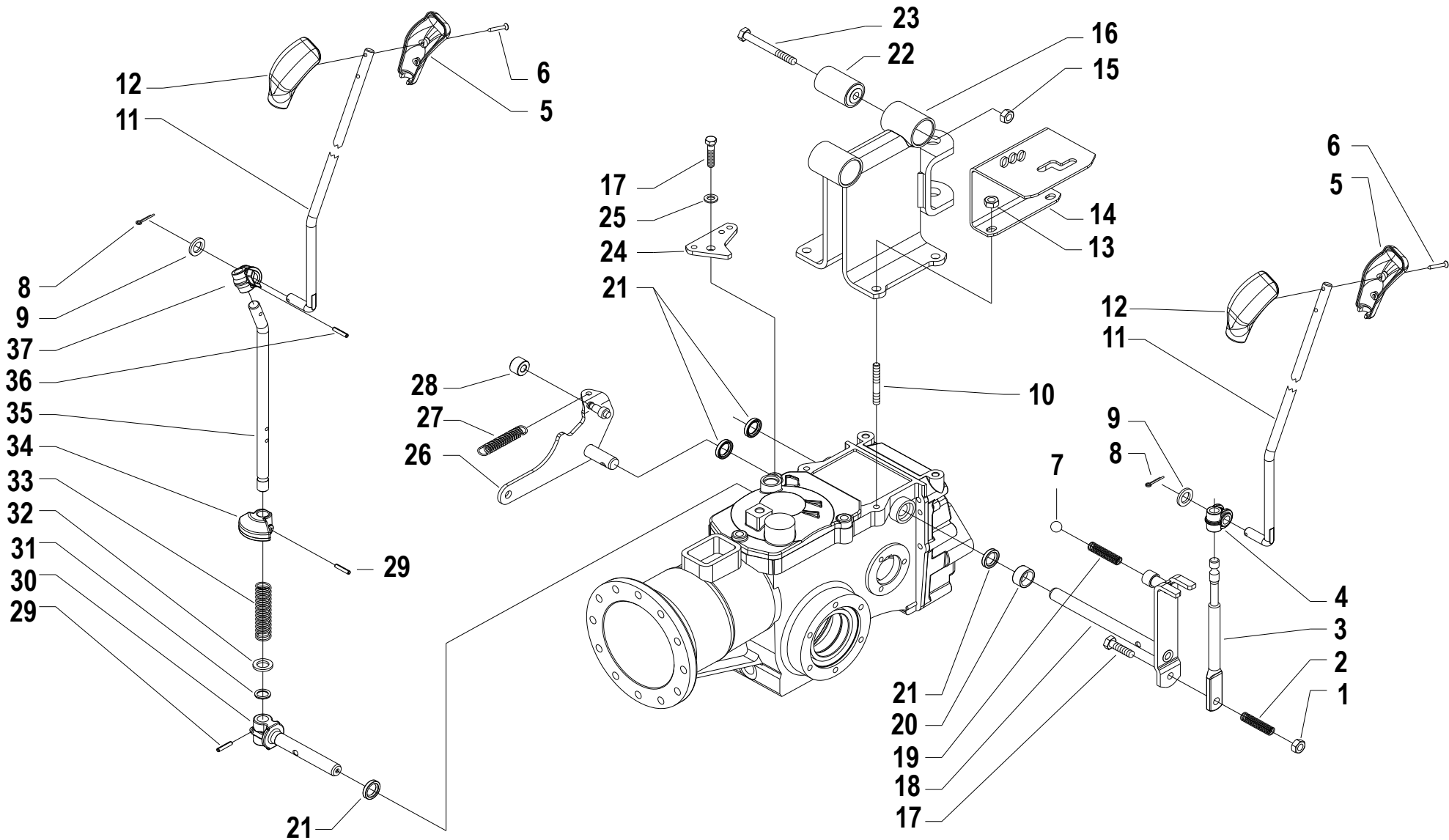

Pos.	Code	Q.ty	Description	Notes
1	31241080	1	SELFLOCK NUT M8	
2	58057232Z	1	SPRING	
3	56157271N	1	COMMAND LEVER	
4	55242528	1	JOINT	
5	55157213	1	GRIP	
6	31100451	1	SCREW 3,5X25	
7	37911532	1	BALL 15/32	
8	34110028	1	SPLIT PIN	
9	31411104	1	WASHER 10,5x18	
10	31312082	1	STUD BOLT M8X38X14X20	
11	56156792N	1	PULL ROD	
12	55157212	1	GRIP	
13	31241084	1	SELFLOCK NUT M8 6S	
14	56156195H	1	GEAR SELECTOR	
15	31241100	1	SELFLOCK NUT M10 6S	
16	59056920	1	SUPPORT	
17	31112152	1	SCREW TE M8X30 UNI 5739 8G	
18	59057251N	1	GEAR LEVER	
19	58043176	1	SPRING	
20	56157257Z	1	SPACER	
21	38211400	1	OIL SEAL 14X22X4	
22	30010142	1	SILENT-BLOCK 10,2X30X45X49	
23	31111217	1	SCREW TE M10X75 UNI 5737 8G	
24	56157274	1	SQUARE	
25	31423084	1	SPRING WASHER 8,4	
26	59057319	1	LEVER	
27	58057273	1	SPRING	
28	55257313	1	ROLLER	
29	34213020	1	ROLL PIN	
30	52357250	1	PIN	
31	38111191	1	O-RING 115 (11,91X2,62)	
32	31414130	1	WASHER 13	
33	F0831193010	1	SPRING DM.15X70	
34	55257321	1	STOP	

SERIAL

CONTROLS

CODE REV

J.01.02.A0011_02

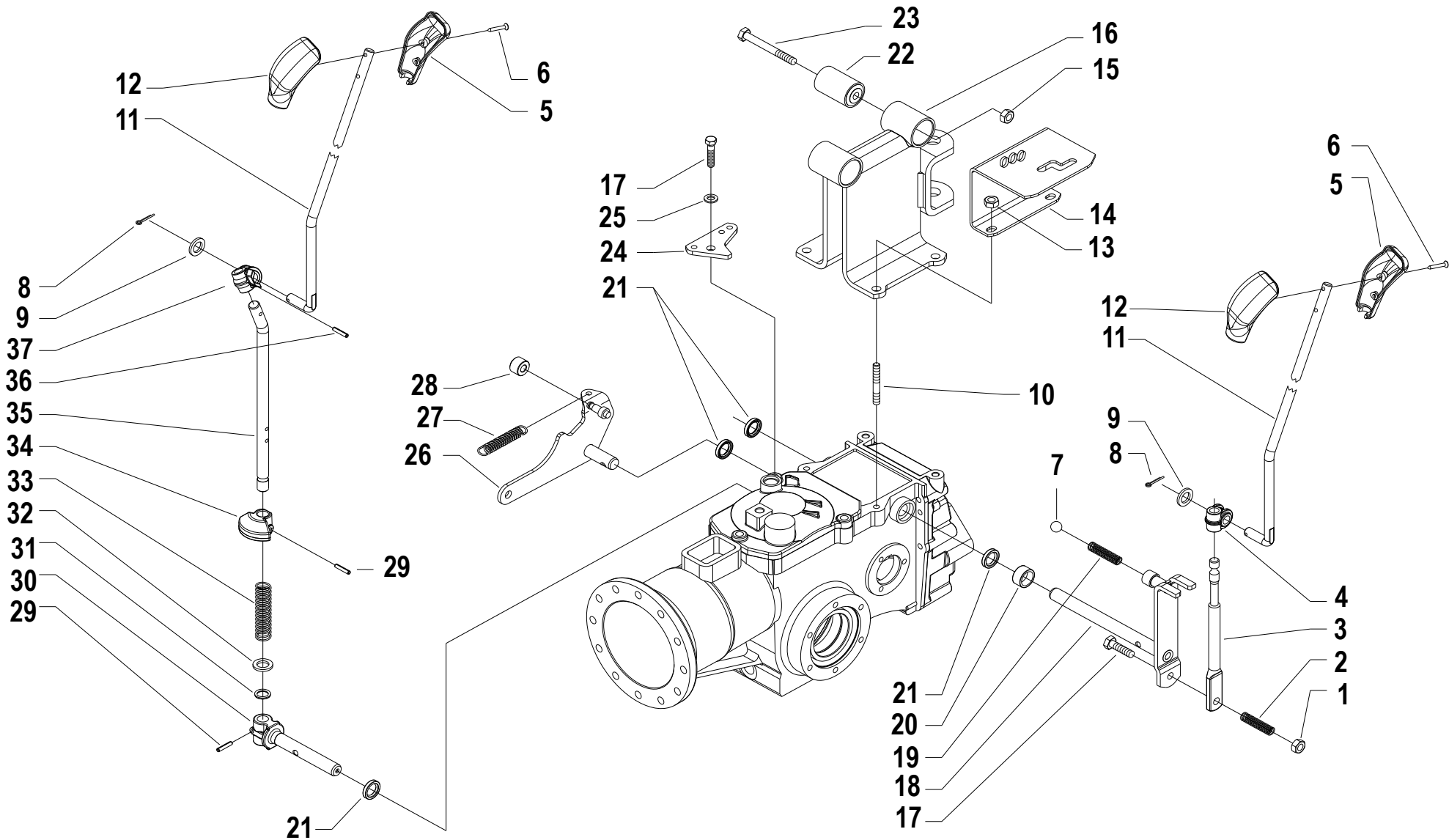

Pos.	Code	Q.ty	Description	Notes
35	56157324N	1	PTO LEVER	
36	34213024	1	ROLL PIN	
37	55248379	1	JOINT	

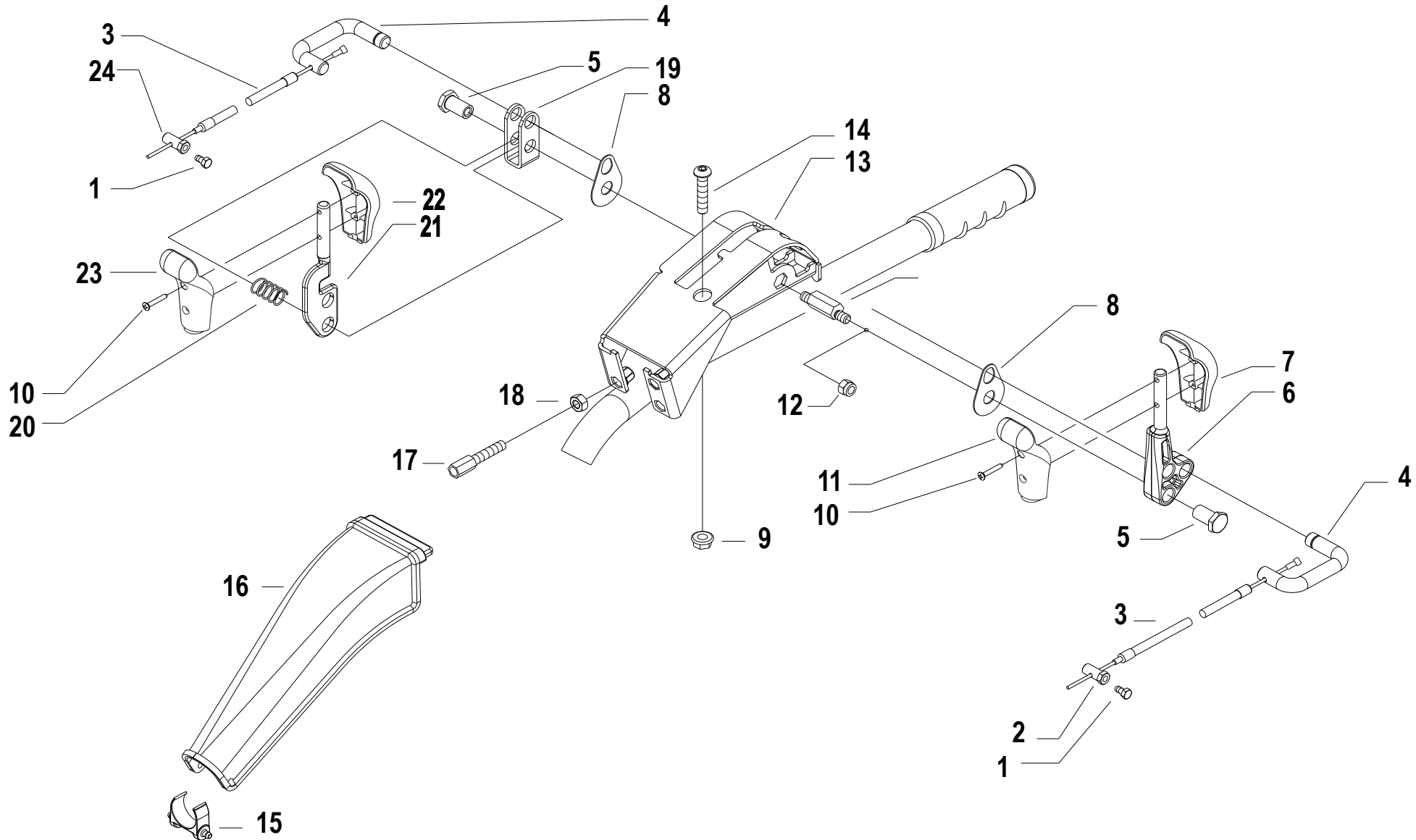

Pos.	Code	Q.ty	Description	Notes
1	31112090	1	SCREW TE M6X16 UNI 5739 8G	
2	56356840Z	1	CLAMPING SCREW	
3	58056848	1	LINE AND SHEATH	
4	56156832Z	1	U BOLT	
5	56148287	1	STUD BOLT	
6	53156860	1	COMMAND LEVER	
7	55157212	1	GRIP	
8	56356833Z	1	SMALL PLATE	
9	31241084	1	SELFLOCK NUT M8 6S	
10	31100451	1	SCREW 3,5X25	
11	55157213	1	GRIP	
12	31241084	1	SELFLOCK NUT M8 6S	
13	59256850	1	SUPPORT	
14	31121020	1	VITE TBCEI M8X40 ISO7380 10K	
15	55256836	1	CROSS MEMBER	
16	55256835	1	PROTECTION COVER	
17	58056595	1	ADJUSTING SCREW	
18	31211080	1	NUT M8	
19	56156859Z	1	FORK	
20	58049830	1	SPRING	
21	52156810Z	1	COMMAND LEVER	
22	55157214	1	GRIP	
23	55157215	1	GRIP	
24	58042200	1	CLAMPING SCREW	

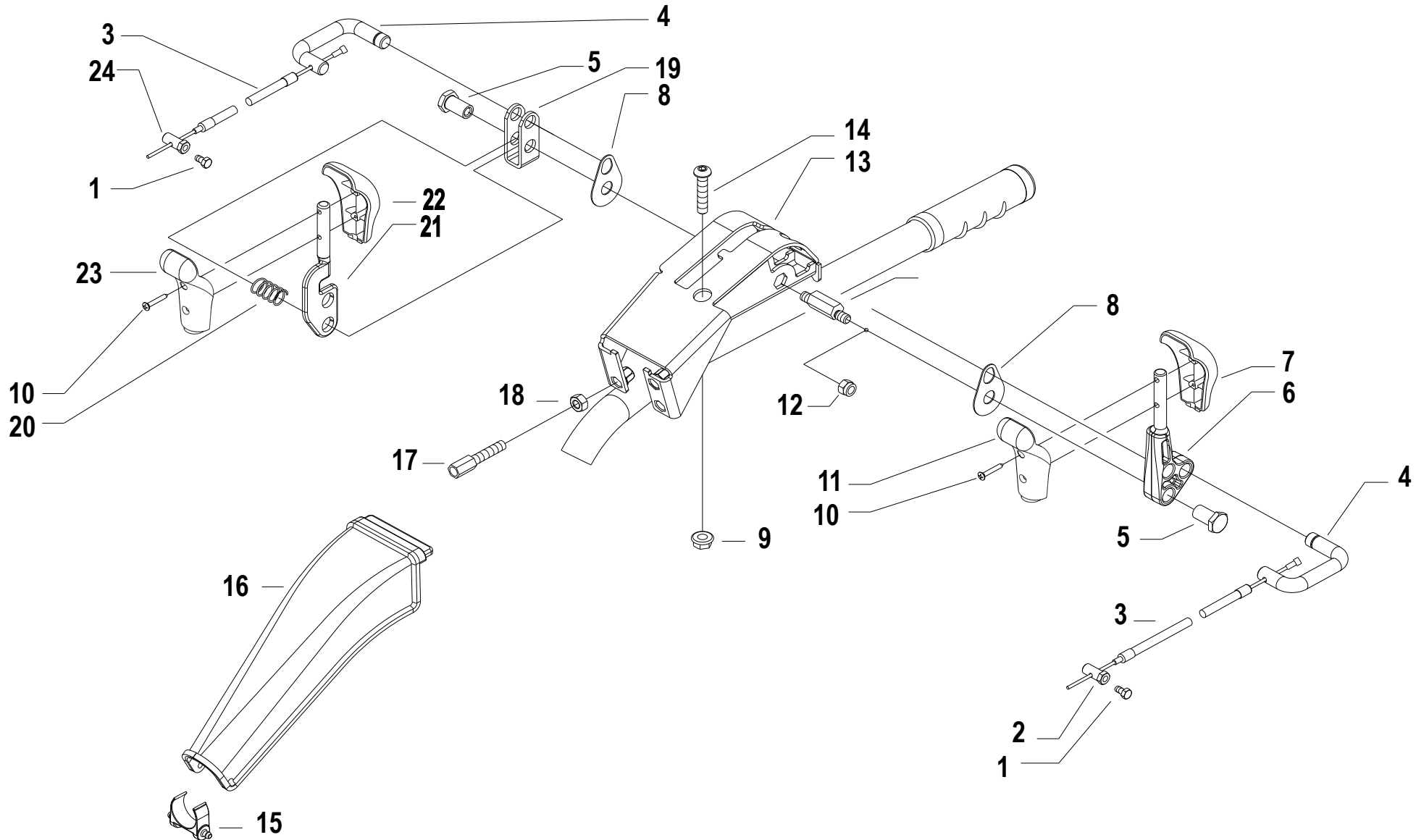

Pos.	Code	Q.ty	Description	Notes
1	31112090	1	SCREW TE M6X16 UNI 5739 8G	
2	56356840Z	1	CLAMPING SCREW	
3	58056848	1	LINE AND SHEATH	
4	56156832Z	1	U BOLT	
5	56148287	1	STUD BOLT	
6	53156860	1	COMMAND LEVER	
7	55157212	1	GRIP	
8	56356833Z	1	SMALL PLATE	
9	31241084	1	SELFLOCK NUT M8 6S	
10	31100451	1	SCREW 3,5X25	
11	55157213	1	GRIP	
12	31241084	1	SELFLOCK NUT M8 6S	
13	59256850	1	SUPPORT	
14	31121020	1	VITE TBCEI M8X40 ISO7380 10K	
15	55256836	1	CROSS MEMBER	
16	55256835	1	PROTECTION COVER	
17	58056595	1	ADJUSTING SCREW	
18	31211080	1	NUT M8	
19	56156859Z	1	FORK	
20	58049830	1	SPRING	
21	52156810Z	1	COMMAND LEVER	
22	55157214	1	GRIP	
23	55157215	1	GRIP	
24	58042200	1	CLAMPING SCREW	

	A	B	C
3.50 - 8" (500)	39113502	39413502	58052325
3.50 - 8"	39113502	39413502	58052326
4.00 - 8"	39114008	39414008	58052326
4.0 - 10"	39114010	39414010	58052327
4.0 - 10"	39114010	39414010	58052289 (FIX) ★
5.0 - 10"	39115010	39415010	58052327
5.0 - 10"	39115010	39415010	58052289 (FIX) ★
6.5 / 8.0 - 12"	39116018	39416018	F0849044070
21 x 11.00 - 8"	39113501	TUBELESS	58052274
20 x 8.00 - 10"	39118021 (TR)	39416025	58052281
20 x 8.00 - 10"	39118020 (GA)	39415010	58052280 (S MUSTER)
16 x 6.50 - 8"	39111608	39411608	58052297 ★

92457794

KIT GEMELLAGGIO PER 4.0-10" / 5.0-10"
 TWINNING KIT FOR 4.0-10" / 5.0-10"
 JUMELAGE KIT POUR 4.0-10" / 5.0-10"
 KIT GEMELOS POR 4.0-10" / 5.0-10"
 ZWILLINGSKIT 4.0-10" / 5.0-10"

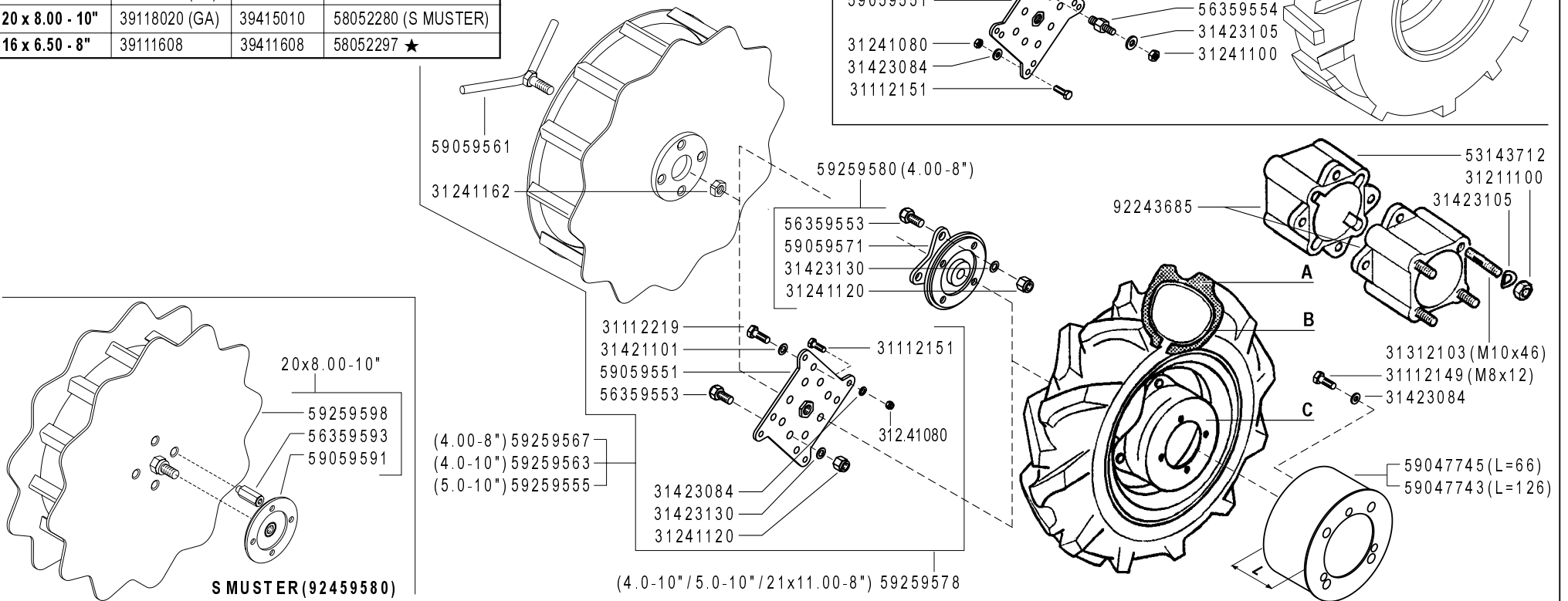

FERRARI

500 serie GRIFON

WHEELS
RUEDAS

RUOTE

ROUES
RÄDER

DALLA MACCHINA
DE LA MAQUINA
DE LA MACHINE
FROM THE MACHINE
AB DER MASCHINE

★ N.

AGGIORNAMENTO
REVISION
MISE A JOUR
APLAZAMIENTO
ANPASSUNG

L01

01/2008

Rev.
2

ZENNE

Pos.	Code	Q.ty	Description	Notes
31112149	31112149	1	SCREW TE M8X12 UNI 5739 8G	
31112151	31112151	1	SCREW TE M8X25 UNI 5739 8G	
31112219	31112219	1	SCREW TE M10X25 UNI 5739	
31211100	31211100	1	NUT M10	
31241080	31241080	1	SELFLOCK NUT M8	
31241100	31241100	1	SELFLOCK NUT M10 6S	
31241120	31241120	1	SELFLOCK NUT M12	
31241162	31241162	1	SELFLOCK NUT	
31312103	31312103	1	STUD BOLT M10X46X24X16	
31421101	31421101	1	WASHER	
31423084	31423084	1	SPRING WASHER 8,4	
31423105	31423105	1	SPRING WASHER 10,5	
31423130	31423130	1	SPRING WASHER 13	
39111608	39111608	1	TYRE 16X6.50-8 4PR	
39113501	39113501	1	TYRE 21X11.00-8	
39113502	39113502	1	TYRE 3.50-8 2PR	
39114008	39114008	1	TYRE 4.00-8 2PR	
39114010	39114010	1	TYRE 4.0-10 2PR	
39115010	39115010	1	TYRE 5.00-10 2PR	
39116018	39116018	1	TYRE 6.5/80-12 2PR	
39118020	39118020	1	TYRE 20X8.00-10 4PR	
39118021	39118021	1	COVER	
39411608	39411608	1	INNER TUBE	
39413502	39413502	1	INNER TUBE	
39414008	39414008	1	INNER TUBE	
39414010	39414010	1	INNER TUBE	
39415010	39415010	1	INNER TUBE	
39416018	39416018	1	INNER TUBE	
39416025	39416025	1	INNER TUBE	
53143712	53143712	1	SPACER	
56359553	56359553	1	PIN	
56359554	56359554	1	PIN	
56359593	56359593	1	DRIVING PIN	
58052274	58052274	1	RIM	

SERIAL

WHEELS

CODE REV

L01_2_60486

	A	B	C
3.50 - 8" (500)	39113502	39413502	58052325
3.50 - 8"	39113502	39413502	58052326
4.00 - 8"	39114008	39414008	58052326
4.0 - 10"	39114010	39414010	58052327
4.0 - 10"	39114010	39414010	58052289 (FIX) ★
5.0 - 10"	39115010	39415010	58052327
5.0 - 10"	39115010	39415010	58052289 (FIX) ★
6.5 / 8.0 - 12"	39116018	39416018	F0849044070
21 x 11.00 - 8"	39113501	TUBELESS	58052274
20 x 8.00 - 10"	39118021 (TR)	39416025	58052281
20 x 8.00 - 10"	39118020 (GA)	39415010	58052280 (S MUSTER)
16 x 6.50 - 8"	39111608	39411608	58052297 ★

92457794

KIT GEMELLAGGIO PER 4.0-10" / 5.0-10"
 TWINNING KIT FOR 4.0-10" / 5.0-10"
 JUMELAGE KIT POUR 4.0-10" / 5.0-10"
 KIT GEMELOS POR 4.0-10" / 5.0-10"
 ZWILLINGSKIT 4.0-10" / 5.0-10"

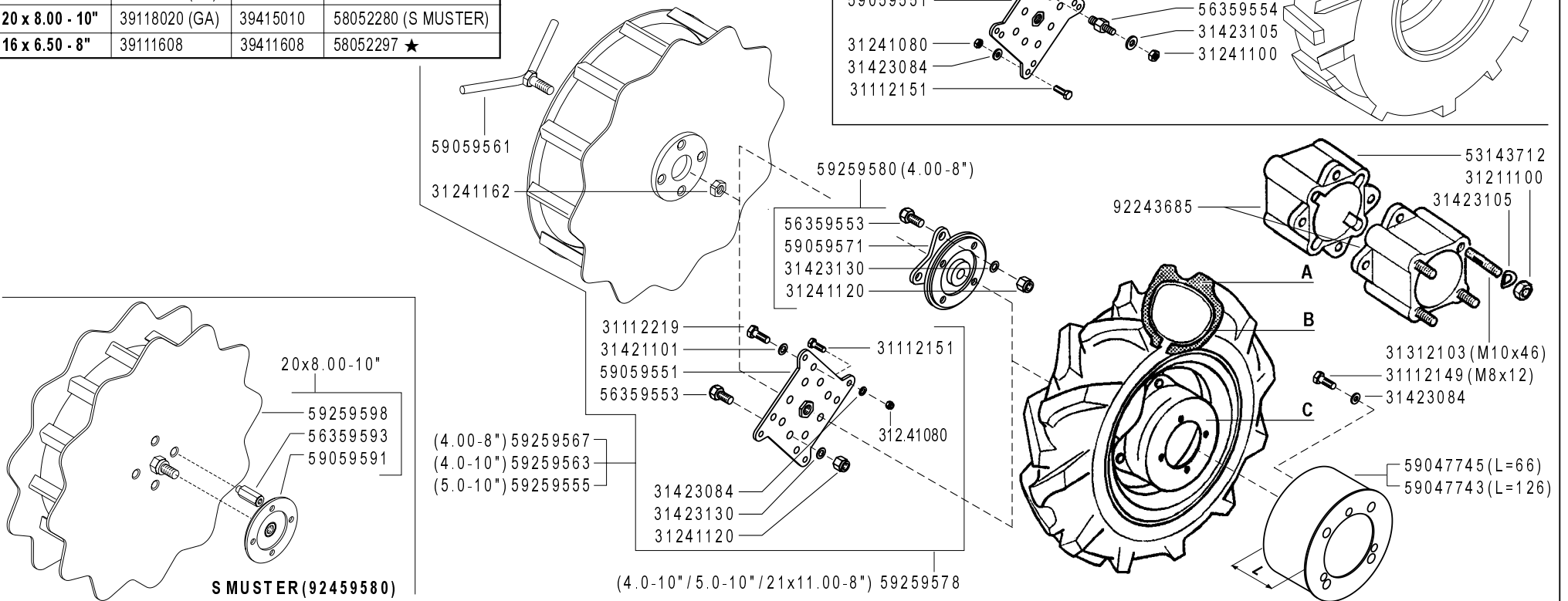

FERRARI

500 serie GRIFON

WHEELS
RUEDAS

RUOTE

ROUES
RÄDER

DALLA MACCHINA
DE LA MAQUINA
DE LA MACHINE
FROM THE MACHINE
AB DER MASCHINE

★ N.

AGGIORNAMENTO
REVISION
MISE A JOUR
APLAZAMIENTO
ANPASSUNG

L01

Rev.
2

01/2008

ZENNE

Pos.	Code	Q.ty	Description	Notes
58052280	58052280	1	RIM	
58052281	58052281	1	RIM	
58052289	58052289	1	RIM	
58052297	58052297	1	RIM	
58052325	58052325	1	RIM	
58052326	58052326	1	RIM	
58052327	58052327	1	RIM	
59047743	59047743	1	HUBCOVER	
59047745	59047745	1	HUBCOVER	
59059551	59059551	1	FLANGE	
59059561	59059561	1	SCREW	
59059571	59059571	1	FLANGE	
59059591	59059591	1	SPACER	
59259555	59259555	1	SUPER-BITE WHEEL X 5.00-10	
59259563	59259563	1	WHEEL	
59259567	59259567	1	WHEEL	
59259578	59259578	1	FLANGE KIT	
59259580	59259580	1	FLANGE KIT	
59259598	59259598	1	WHEEL	
92243685	92243685	1	PAIR WHEEL SPACERS 6 CM	
92457794	92457794	1	ADAPTOR PLATES 10 WHEELS (PAIR)	
92459580	92459580	1	COPPIA R.MARGHER.20X8.0-10 FER	
F0849044	F0849044070	1	WHEEL DISC	

	A	B	C
3.50 - 8" (500)	39113502	39413502	58043370 ★
3.50 - 8"	39113502	39413502	58043250 ★
4.00 - 8"	39114008	39414008	58043250 ★
4.0 - 10"	39114010	39415010 ★(1)	58048330 ★
5.0 - 10"	39115010	39415010	58048330 ★
6.5 / 80 - 12"	39116018	39416018	58044804 ★
21 x 11.00 - 8"	39113501	TUBELESS	58057795 ★
20 x 8.00 - 10"	39118021 (TR)	39416025	58057799 ★
20 x 8.00 - 10"	39118020 (GA)	39415010	58057797 ★ (S MUSTER)
16 x 6.50 - 8"	39111665 ★(2)	39411608	58057839 ★

(1) sostituisce 39414010
(2) ERRATA CORRIGE

92457794
KIT GEMELLAGGIO PER 4.0-10" / 5.0-10"
TWINNING KIT FOR 4.0-10" / 5.0-10"
JUMELAGE KIT POUR 4.0-10" / 5.0-10"
KIT GEMELOS POR 4.0-10" / 5.0-10"
ZWILLINGSKIT 4.0-10" / 5.0-10"

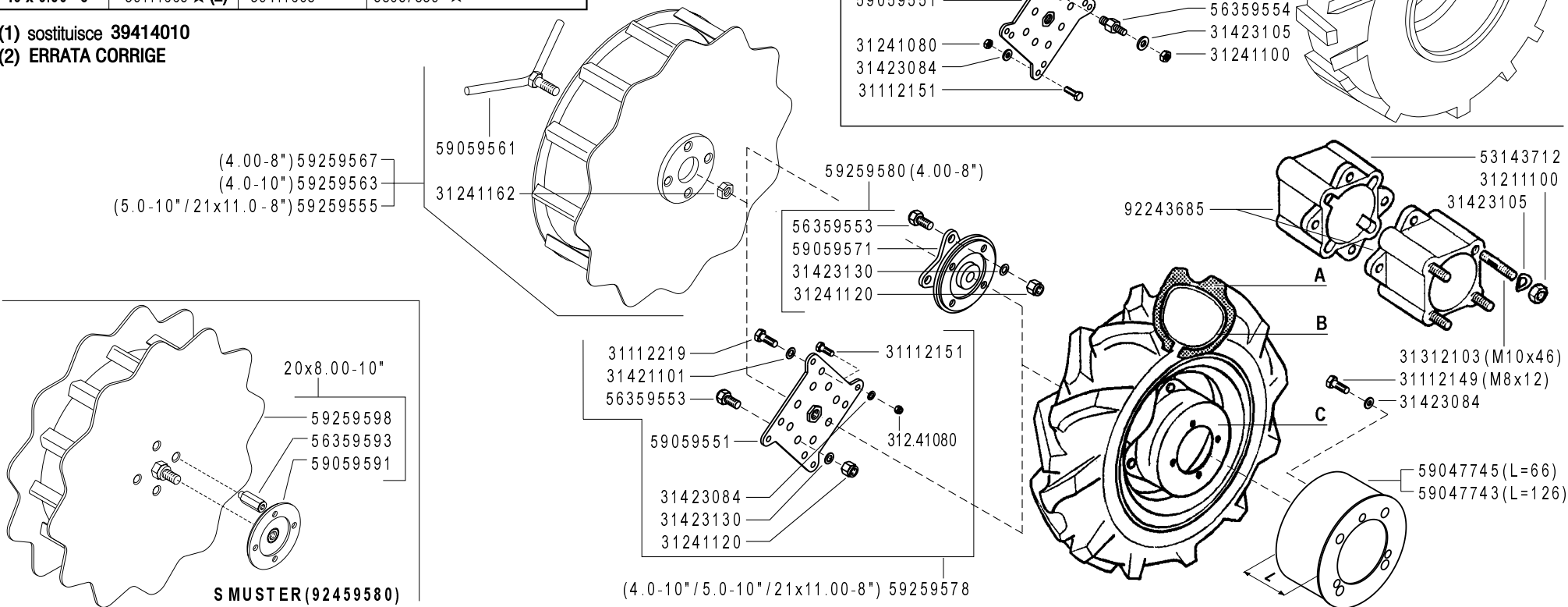

FERRARI

500 serie **GRIFON**

RUOTE

WHEELS
RUEDAS

ROUES
RÄDER

DALLA MACCHINA
DE LA MAQUINA
DE LA MACHINE
FROM THE MACHINE
AB DER MASCHINE

★ N.

AGGIORNAMENTO
REVISION
MISE A JOUR
APLAZAMIENTO
ANPASSUNG

L01

06/2010

Rev. **3**

ZENNE

Pos.	Code	Q.ty	Description	Notes
31112151	31112151	1	SCREW TE M8X25 UNI 5739 8G	
31112219	31112219	1	SCREW TE M10X25 UNI 5739	
31211100	31211100	1	NUT M10	
31241080	31241080	1	SELFLOCK NUT M8	
31241100	31241100	1	SELFLOCK NUT M10 6S	
31241120	31241120	1	SELFLOCK NUT M12	
31241162	31241162	1	SELFLOCK NUT	
31312103	31312103	1	STUD BOLT M10X46X24X16	
31421101	31421101	1	WASHER	
31423084	31423084	1	SPRING WASHER 8,4	
31423105	31423105	1	SPRING WASHER 10,5	
31423130	31423130	1	SPRING WASHER 13	
39111608	39111608	1	TYRE 16X6.50-8 4PR	
39111665	39111665	1	TYRE 16X6.50-8 4PR	
39113501	39113501	1	TYRE 21X11.00-8	
39113502	39113502	1	TYRE 3.50-8 2PR	
39114008	39114008	1	TYRE 4.00-8 2PR	
39114010	39114010	1	TYRE 4.0-10 2PR	
39115010	39115010	1	TYRE 5.00-10 2PR	
39116018	39116018	1	TYRE 6.5/80-12 2PR	
39118020	39118020	1	TYRE 20X8.00-10 4PR	
39118021	39118021	1	COVER	
39411608	39411608	1	INNER TUBE	
39413502	39413502	1	INNER TUBE	
39414008	39414008	1	INNER TUBE	
39415010	39415010	1	INNER TUBE	
39416018	39416018	1	INNER TUBE	
39416025	39416025	1	INNER TUBE	
53143712	53143712	1	SPACER	
56359553	56359553	1	PIN	
56359554	56359554	1	PIN	
56359593	56359593	1	DRIVING PIN	
58043250	58043250	1	RIM	
58043370	58043370	1	RIM	

SERIAL

WHEELS

CODE REV

L01_3_90714

	A	B	C
3.50 - 8" (500)	39113502	39413502	58043370 ★
3.50 - 8"	39113502	39413502	58043250 ★
4.00 - 8"	39114008	39414008	58043250 ★
4.0 - 10"	39114010	39415010 ★(1)	58048330 ★
5.0 - 10"	39115010	39415010	58048330 ★
6.5 / 80 - 12"	39116018	39416018	58044804 ★
21 x 11.00 - 8"	39113501	TUBELESS	58057795 ★
20 x 8.00 - 10"	39118021 (TR)	39416025	58057799 ★
20 x 8.00 - 10"	39118020 (GA)	39415010	58057797 ★ (S MUSTER)
16 x 6.50 - 8"	39111665 ★(2)	39411608	58057839 ★

(1) sostituisce 39414010
(2) ERRATA CORRIGE

92457794
KIT GEMELLAGGIO PER 4.0-10" / 5.0-10"
TWINNING KIT FOR 4.0-10" / 5.0-10"
JUMELAGE KIT POUR 4.0-10" / 5.0-10"
KIT GEMELOS POR 4.0-10" / 5.0-10"
ZWILLINGSKIT 4.0-10" / 5.0-10"

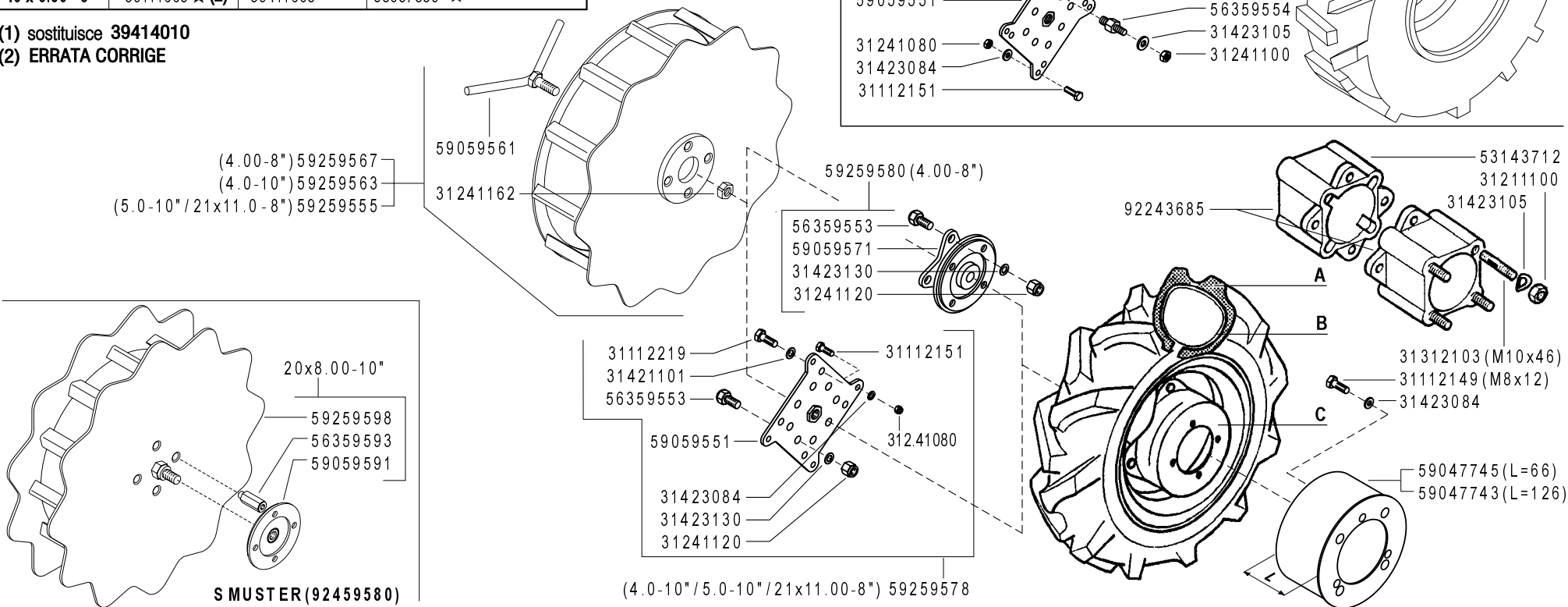

FERRARI

500 serie **GRIFON**

RUOTE

WHEELS
RUEDAS

ROUES
RÄDER

DALLA MACCHINA
DE LA MAQUINA
DE LA MACHINE
FROM THE MACHINE
AB DER MASCHINE

★ N.

AGGIORNAMENTO
REVISION
MISE A JOUR
APLAZAMIENTO
ANPASSUNG

L01

06/2010

Rev.
3

ZENNE

Pos.	Code	Q.ty	Description	Notes
58044804	58044804	1	RIM	
58048330	58048330	1	RIM	
58057795	58057795	1	RIM	
58057797	58057797	1	RIM	
58057799	58057799	1	RIM	
58057839	58057839	1	RIM	
59047743	59047743	1	HUBCOVER	
59047745	59047745	1	HUBCOVER	
59059551	59059551	1	FLANGE	
59059561	59059561	1	SCREW	
59059571	59059571	1	FLANGE	
59059591	59059591	1	SPACER	
59259555	59259555	1	SUPER-BITE WHEEL X 5.00-10	
59259563	59259563	1	WHEEL	
59259567	59259567	1	WHEEL	
59259578	59259578	1	FLANGE KIT	
59259580	59259580	1	FLANGE KIT	
59259598	59259598	1	WHEEL	
92243685	92243685	1	PAIR WHEEL SPACERS 6 CM	
92457794	92457794	1	ADAPTOR PLATES 10 WHEELS (PAIR)	
92459580	92459580	1	COPPIA R.MARGHER.20X8.0-10 FER	

500 GRIFON

58052165

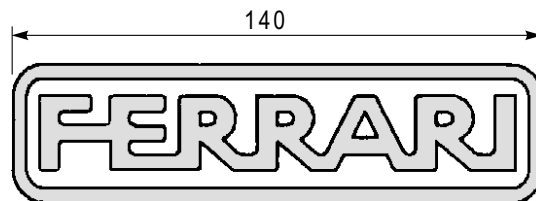

58052029



58052160

515 GRIFON

58052157

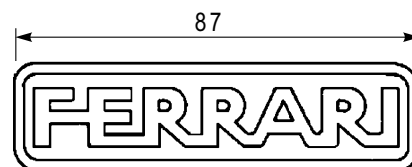

58052019 ★

515L GRIFON

58052158

520 GRIFON

58052162

515S GRIFON

58052159

530 GRIFON

58052163

515SL GRIFON

58052167 ★

530S GRIFON

58052164

FERRARI

500 serie GRIFON

ADESIVI

STICKERS
ADHESIVOS

AUTOCOLLANTS
AUFKLEBES

DALLA MACCHINA
DE LA MAQUINA
DE LA MACHINE
FROM THE MACHINE
AB DER MASCHINE

AGGIORNAMENTO

REVISION

MISE A JOUR

APLAZAMIENTO

ANPASSUNG

★N.

M01

Rev.
2

02/2009

ZENNE

Pos.	Code	Q.ty	Description	Notes
58052019	58052019	1	DECAL	
58052029	58052029	1	DECAL	
58052157	58052157	1	DECAL	
58052158	58052158	1	DECAL	
58052159	58052159	1	DECAL	
58052160	58052160	1	DECAL	
58052162	58052162	1	DECAL	
58052163	58052163	1	DECAL	
58052164	58052164	1	DECAL	
58052165	58052165	1	DECAL	
58052167	58052167	1	DECAL	

500 GRIFON 58052165

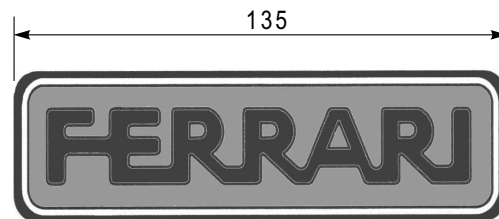

53052176 ★

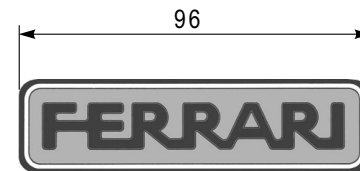

53052175 ★

515 GRIFON 58052183 ★

530 S

58052190 ★

515L GRIFON 58052184 ★

520 GRIFON 58052187 ★

515S GRIFON 58052185 ★

530 GRIFON 58052188 ★

515SL GRIFON 58052186 ★

530S GRIFON 58052189 ★

FERRARI

500 serie **GRIFON**

ADESIVI

STICKERS
ADHESIVOS

AUTOCOLLANTS
AUFKLEBES

DALLA MACCHINA
DE LA MAQUINA
DE LA MACHINE
FROM THE MACHINE
AB DER MASCHINE

AGGIORNAMENTO

REVISION

MISE A JOUR

APLAZAMIENTO

ANPASSUNG

★N.

M01

Rev.
3

11/2010

ZENNE

Pos.	Code	Q.ty	Description	Notes
53052175	53052175	1	MARCHIO FERRARI MEDIO	
53052176	53052176	1	MARCHIO FERRARI GRANDE	
58052165	58052165	1	DECAL	
58052183	58052183	1	DECAL	
58052184	58052184	1	DECAL	
58052185	58052185	1	DECAL	
58052186	58052186	1	DECAL	
58052187	58052187	1	DECAL	
58052188	58052188	1	DECAL	
58052189	58052189	1	DECAL	
58052190	58052190	1	DECAL	



580.57698

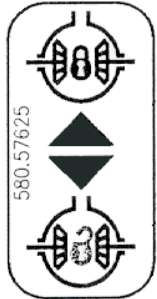

580.57625



580.57773

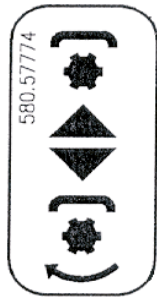

580.57774



580.57772

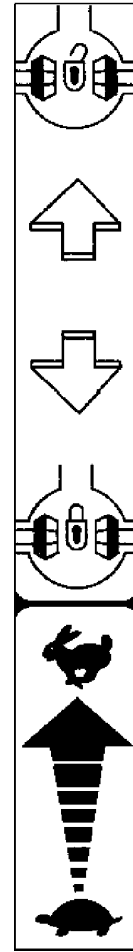

580.57688★



580.57706



580.57767



580.57768

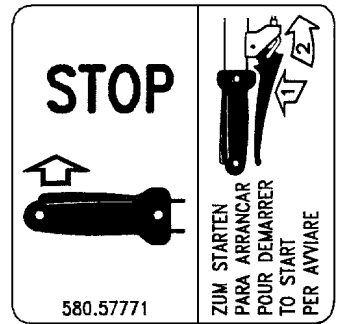

580.57771



580.57676



580.57712



580.57678



580.57722

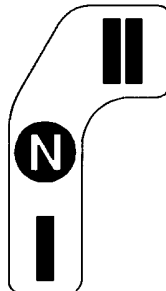

580.57732



580.93089



580.57724



580.57770

FERRARI

500 serie GRIFON

ADESIVI

STICKERS
ADHESIVOS

AUTOCOLLANTS
AUFKLEBES

DALLA MACCHINA
DE LA MAQUINA
DE LA MACHINE
FROM THE MACHINE
AB DER MASCHINE

AGGIORNAMENTO
REVISION
MISE A JOUR
APLAZAMIENTO
ANPASSUNG

★ N.

Rev. **M02** 2

02/2009

ZENNE

Pos.	Code	Q.ty	Description	Notes
58046912	58046912	1	DECAL	
58057625	58057625	1	DECAL	
58057676	58057676	1	DECAL	
58057678	58057678	1	DECAL	
58057688	58057688	1	DECAL	
58057698	58057698	1	DECAL	
58057706	58057706	1	DECAL	
58057712	58057712	1	DECAL	
58057722	58057722	1	DECAL	
58057724	58057724	1	DECAL	
58057732	58057732	1	DECAL	
58057746	58057746	1	DECAL	
58057747	58057747	1	DECAL	
58057748	58057748	1	DECAL	
58057767	58057767	1	DECAL	
58057768	58057768	1	DECAL	
58057770	58057770	1	DECAL	
58057771	58057771	1	DECAL	
58057772	58057772	1	DECAL	
58057773	58057773	1	DECAL	
58057774	58057774	1	DECAL	
58093089	58093089	1	DECAL	

4
3
2
1

580.57458

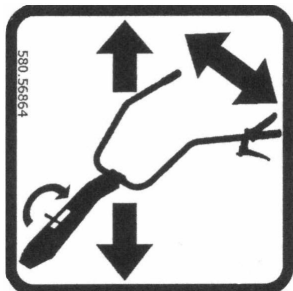

58056864

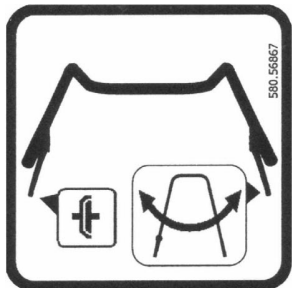

58056867

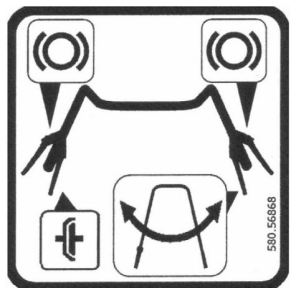

58056868

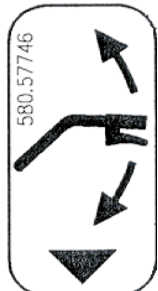

58057746

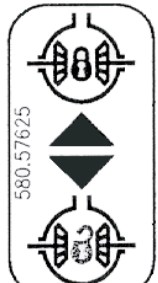

58057625



58093089



58057747

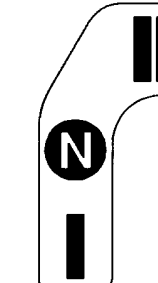

58057732

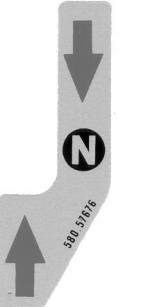

58057676

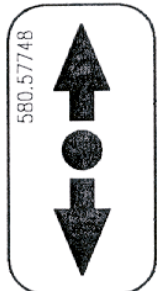

58057748



58057774



58057773

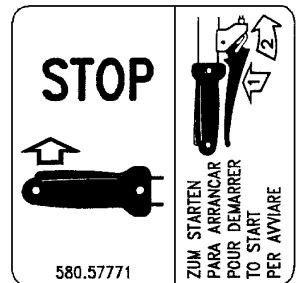

580.57771



580.57772



58057767



58057768



58057678



58057770



58057722



58057724

ZUM STARTEN

- KUPPLUNGHEBEL ANHAKEN, (SIEHE) AUFKLEBER AUF DEM LENKHOLM).
 - GASHEBEL ZUR MITTE EINSTELLEN.
 - BENZINHAHN OFFNEN (WENN VORHANDEN).
 - CHOKE SCHLIESSEN (BEI KALTEM MOTOR).
- DEN FUSS IN DIE RICHTIGE STELLUNG SETZEN.



ZUM STARTEN

- DEN SEIL AUF DIE STARTSCHEIBE AUFWICKELN (WENN KEIN REVERSIERSTARTER VORHANDEN IST).
- DER STARTERGRIF IN ENTSCHLOSSENER WEISE ZIEHEN, BEI DEM ELEKTROSTARTER SCHLUSSEL DREHEN.
- CHOKE DEFNEN.

FERRARI

500 serie GRIFON

ADESIVI

STICKERS
ADHESIVOS

AUTOCOLLANTS
AUFKLEBES

DALLA MACCHINA
DE LA MAQUINA
FROM THE MACHINE
AB DER MASCHINE

★ N.

867450 (520-530-S)
863996 (515L-S-SL)
864056 (515)

M02

Rev.
3

11/2010

ZENNE

Pos.	Code	Q.ty	Description	Notes
58046932	58046932	1	DECAL	
58056864	58056864	1	DECAL	
58056867	58056867	1	DECAL	
58056868	58056868	1	DECAL	
58057458	58057458	1	DECAL	
58057625	58057625	1	DECAL	
58057676	58057676	1	DECAL	
58057678	58057678	1	DECAL	
58057722	58057722	1	DECAL	
58057724	58057724	1	DECAL	
58057732	58057732	1	DECAL	
58057746	58057746	1	DECAL	
58057747	58057747	1	DECAL	
58057748	58057748	1	DECAL	
58057767	58057767	1	DECAL	
58057768	58057768	1	DECAL	
58057770	58057770	1	DECAL	
58057771	58057771	1	DECAL	
58057772	58057772	1	DECAL	
58057773	58057773	1	DECAL	
58057774	58057774	1	DECAL	
58093089	58093089	1	DECAL	